



MODEL SHOWN WITH EXPOSED DUCT CONNECTION



LEGS SHOWN ARE OPTIONAL

Standard Design Features

- All stainless steel construction with heliarc welded seams and joints, ground and polished to a smooth finish
- Deluxe aspirator with reverse flow for additional waste removal: "reverse flow" feature instantly relieves suction clogging by providing a reverse pressure of water
- Hot and cold water fixture with convenient goose-neck faucet and wristblade handles.
- Spray hose assembly with cold water control valve, nozzle and 10 ft./3 m. of flexible hose
- Dissecting area rinse assembly with cold water valve
- Heavy-duty commercial waste disposal, 1/2 hp
- Large instrument drawer
- Large radii on all inside corners for easy cleaning and required sanitation.
- Large single-compartment sink with rapid and positive drainage.
- Cart-to-sink locking mechanism with slide latch which can be accessed from either side of the carrier
- Waterproof electrical outlets and switches
- Plumbing and electrical lines are factory installed and require only minimum installation.
- Complete backsiphon protection provided by reduced pressure principle assembly
- Exhaust duct at rear of unit have an adjustable 8 in./20 cm. X 10 in./25 cm. grill
- Fluorescent light fixture over the work area
- Concealed exhaust connection with grill

Plumbing fixtures can be located in varying positions depending on your desired work environment

For Easy Transporting
Add a 600017FRC Autopsy
Carrier or any Carrier that will
fit Your Needs



Call for more information
(800) 410-0100

MODEL 1036-10

WALL MOUNT AUTOPSY STATION, LEFT SINK

MODEL 1036-10

LAYOUT DRAWING & OPTIONAL FEATURES

411 North Aerojet Avenue
 Azusa, CA 91702
 www.mortechmfg.com
 Tel (800) 410-0100
 (626) 334-1471
 Fax (626) 334-1704

Optional Accessories

- Heavy-duty commercial disposal (3/4hp, 1hp,2hp)
- CO2 valves / oxygen valves / vacuum valves/compressed air valves
- Dissecting area rinse assembly
- Cart to sink locking mechanism
- Postmortem scale with scale pole and bracket
- Stainless steel shelf for platform type scale
- Raised instrument dissecting tray
- Exhaust duct for connection to building ventilation system for exterior connection at top of station
- Formalin dispensing and/or collection system
- Electric aspiration system
- Emergency eyewash assembly
- Flip eyewash assembly
- Organ rinse basket
- Integral raised dissecting area per your requirements
- Stainless steel leg assembly
- Evidence screen
- Dissecting boards
- Magnetic instrument holder
- Full length specimen shelf, 12 in./30 cm.
- Custom layout and design
- 316 stainless steel
- Handicap accessible

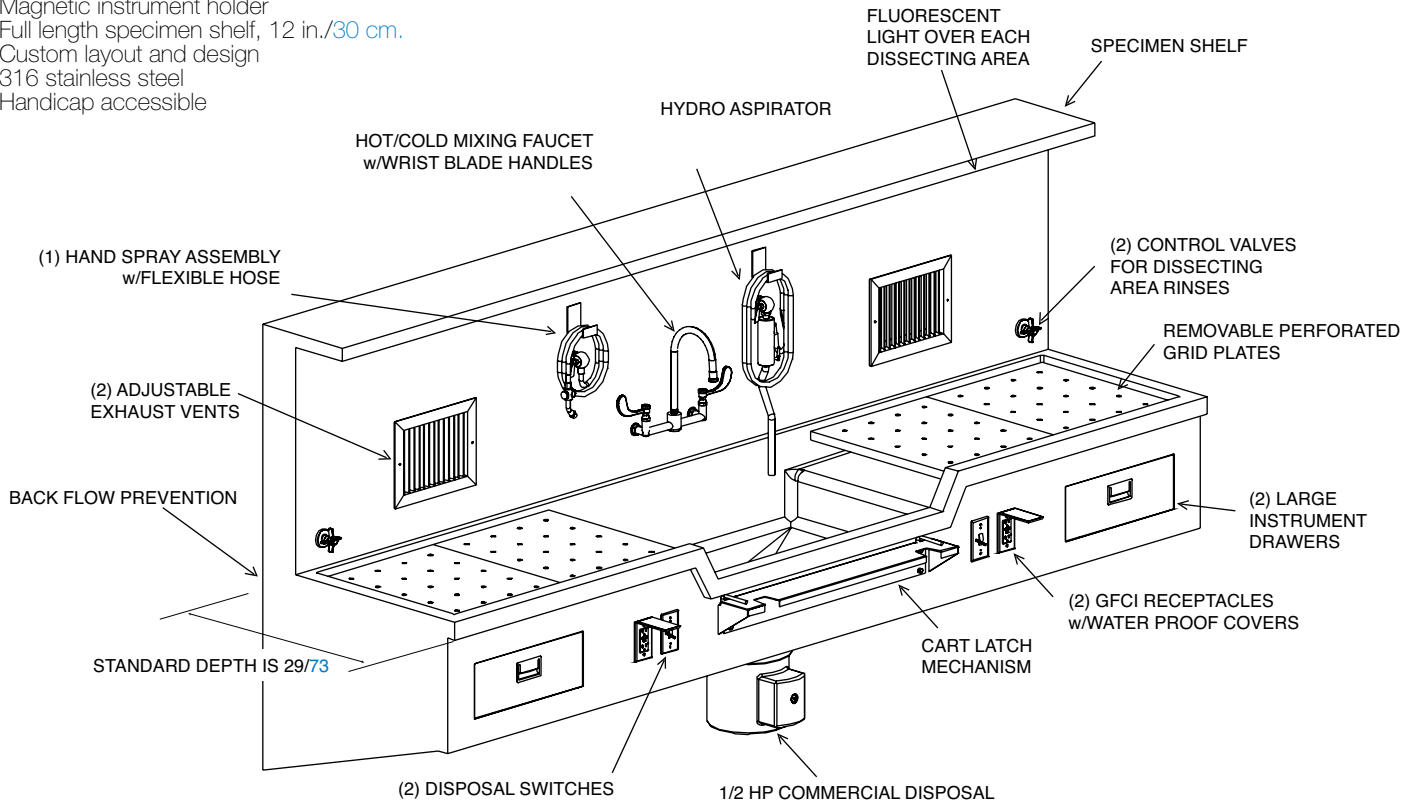
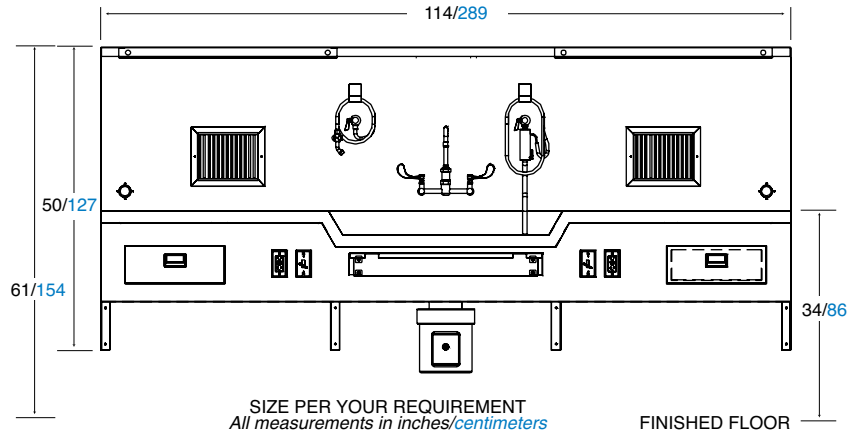

Options based on available space.

When planning an order, please call us and we will assist you in determining which options to choose.



EMERGENCY EYEWASH HOSE ASSEMBLY



FLUORESCENT LIGHT FIXTURE



RAISED DISSECTING AREA



SCALE POLE & MOUNTING BRACKET



FLIP EYEWASH



DISSECTING AREA RINSE ASSEMBLY

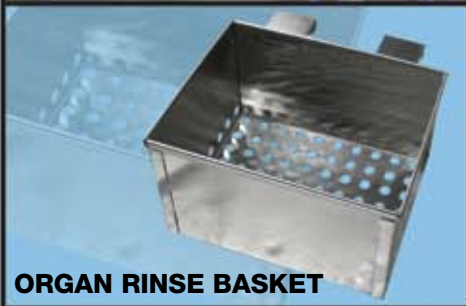

ORGAN RINSE BASKET



EVIDENCE SCREEN



MAGNETIC INSTRUMENT HOLDER

EMERGENCY EYEWASH HOSE ASSEMBLY

Hand control spray to provide a gentle flow of water to rinse eyes of foreign debris. Includes bracket for spray handle and coiled hose.

SCALE POLE & MOUNTING BRACKET

Stainless steel scale pole with mounting bracket for use with standard hanging autopsy scales. Pole can swivel left to right and includes locking knob to keep in desired position. Can be positioned to left, right or center of station depending on your preference.

ORGAN RINSE BASKET

The organ rinse sink basket is designed to hang on the interior of the sink basin for rinsing organs. It is fabricated of stainless steel with a perforated bottom. Order Model LW487

FLUORESCENT LIGHT FIXTURE

Low profile fixtures to provide additional lighting to dissecting area. Units are waterproof and UL listed.

FLIP EYEWASH

Wall mounted polished chrome-plated brass single action pull down to activate eye/face wash features twin plastic eye/face wash heads. Unit is designed for mounting on rear of sink.

EVIDENCE SCREEN

The screen is designed to prevent evidence from being accidentally washed down the drain. It is fabricated entirely from perforated stainless steel with a stainless steel pull handle. It is designed for use in 3.5 in. diameter drains.

HANDICAP ACCESSIBLE

We can provide various modifications to the stations to allow for use by handicapped personnel. For example, units can be fabricated with lower dissecting areas or the front panel can be fabricated for wheel chair accessibility. Tell us your requirements and we will provide a solution.

RAISED DISSECTING AREA

On standard models the height for the dissecting area is 34 in./86 cm. from the floor. We can increase the dissecting area height up to 40 in./101 cm. from the floor. This increased height allows taller personnel to work more comfortably since there is no need to bend over to perform dissecting procedures. All current body carriers will still work with the raised dissecting area station. The sink height remains the same. It is only the dissecting area which is raised. This allows all existing carriers to be compatible with the new station.

DISSECTING AREA RINSE ASSEMBLY

Provides a constant flow of water beneath the dissecting area grid plates to wash debris toward sink and drain. Stainless steel tubing and spray nipples provide long lasting use. Includes cold water control valve and back flow protection.

AUTOPSY STATION

FEATURES & ACCESSORIES

411 North Aerojet Avenue
Azusa, CA 91702
www.mortechmfg.com
Tel (800) 410-0100
(626) 334-1471
Fax (626) 334-1704



MAGNETIC INSTRUMENT HOLDER
conveniently store and organize your most commonly used instruments within arms reach

EXHAUST DUCTS
Standard grill size is 10 in./25 cm. x 8 in./20 cm. Any size can be provided per your project requirements. Anodized aluminum and stainless steel finishes are available. Includes adjustable damper to control air flow.

CUSTOM LAYOUT OR DESIGN
We understand that every project is unique. If you have special requirements, we can modify the stations to suit your needs. A custom layout can consist of modification to allow larger or restricted work area, additional utilities, shelving, drawers and ventilation.

DISSECTING BOARDS
Dissecting boards are manufactured from high density polyethylene which provides an excellent cutting surface. All top edges are chamfered and all bottom corners have a non-skid rubber bumper attached. Colors are white and Photo-Blue.

CART TO SINK LOCKING MECHANISM
This unique design securely holds the carrier in position while procedures are performed at the autopsy station. A custom stainless steel cart locking bracket is mounted to the front apron of the autopsy station. A stainless steel slide rod can be locked or unlocked from either side of the carrier. Units are designed for use with all Mortech stainless steel framed carriers.

Standard on all Mortech Autopsy Stations not for use with hydraulic carrier bases.

SCALE SHELF & SS SHELF
Stainless steel scale shelf attached to front of station for use with various platform type scales. Fabricated to your desired size. Receptacle can be provided to provide power to scale indicator.

COMMERCIAL GRADE WASTE DISPOSAL UNITS
Units come standard with 1/2 hp disposal units. Facilities can upgrade to 3/4 hp, 1 or 2 hp disposal units. Units have all internal stainless steel components and swivel impellers.

GAS / AIR / VACUUM COCKS
All brass with chrome plated finish. Visually marked for type of function required.