



**GL115 w/OPTIONAL  
FLAMMABLE CABINET**



**GL125**

The Model GL115 has the same useful features as the Model GL110 with the added bonus of a larger sink basin. The larger sink basin allows the unit to be equipped with an optional disposal unit.

### Standard Design Features:

- Available in two sizes: 48 in./121 cm. long and 60 in./152 cm. long
- All stainless steel construction of the entire work area and all exterior closure panels.
- Integral sink with mixing faucet
- Exhaust duct for connection to building ventilation system with adjustable bellows
- Top mounted fluorescent light fixture
- Incandescent light with 3x magnifier mounted on flexible arm
- Formalin container with spigot
- C-fold paper towel holder, stainless steel
- Magnetic instrument holder
- Polyethylene dissecting board (Photo Blue)

\* All measurements in inches/centimeters



**GL120**

## MODEL **GL115** PATHOLOGY WORKSTATION

# MODEL GL115

## LAYOUT DRAWING & OPTIONAL FEATURES

411 North Aerojet Avenue  
 Azusa, CA 91702  
 www.mortechmfg.com  
 Tel (800) 410-0100  
 (626) 334-1471  
 Fax (626) 334-1704

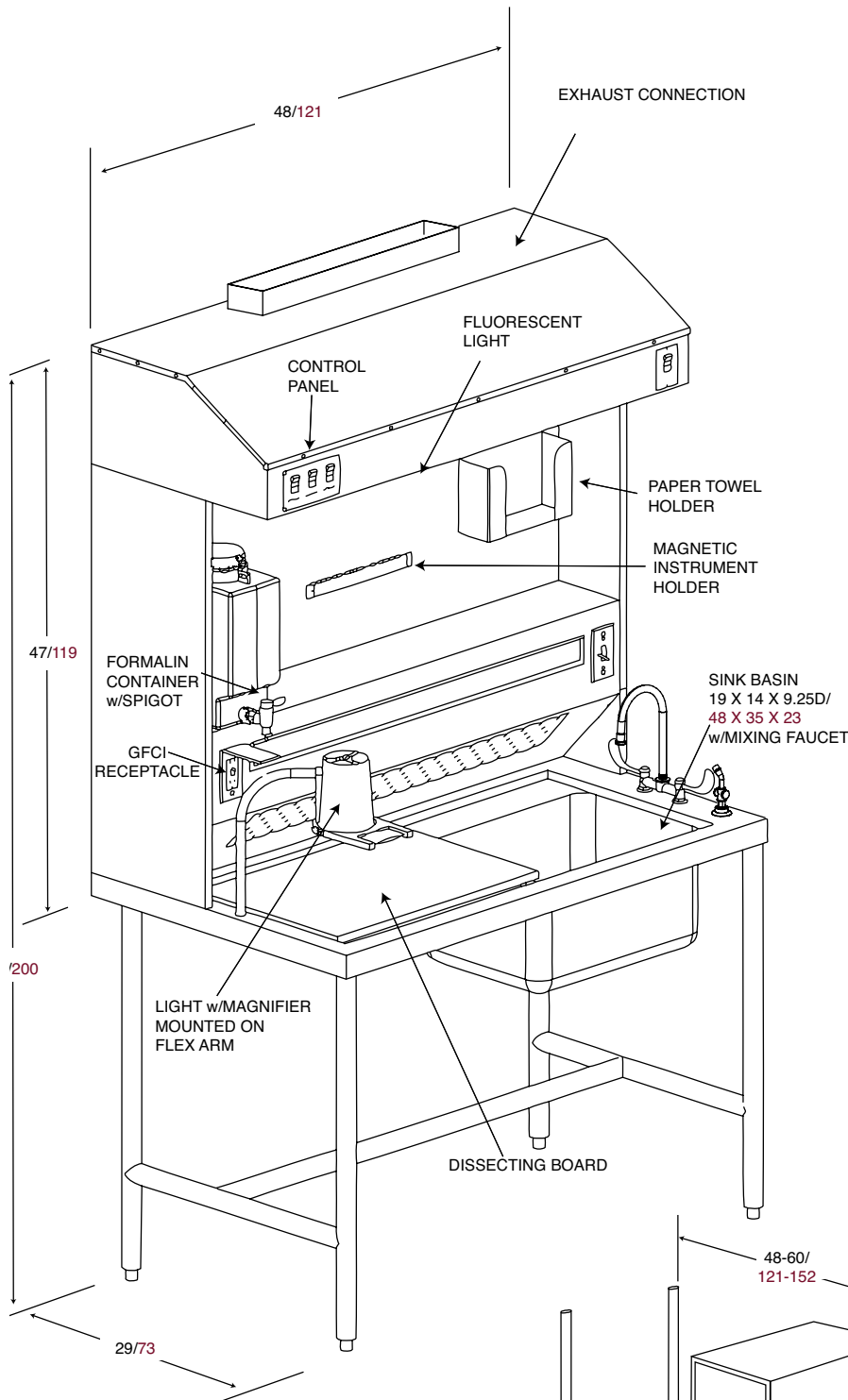

## Optional Accessories

- Heavy-duty commercial disposal (3/4 hp, 1 hp, 2 hp)
- Self Contained Ventilation Assembly
- CO2 valves / oxygen valves / vacuum valves/compressed air valves
- Digital platform scale, 4 lbs./2 kg capacity, economy or premium grades available
- Model GL 120 or Model GL 125 Pathology Station Bases w/cabinet
- Computer monitor and keyboard stand premium or standard grades available
- CPU stand
- Flex arm halogen or incandescent lights
- Plexiglass splash shield
- Hands free controls for water features and disposal
- Cassette holder
- Form holder
- Ventilated trash container
- Replacement filters Model GL112
- Camera mount facilities
- Video camera mount
- Removable measuring rule
- Dictation machine w/footswitch or voice operations
- Dictation equipment stand
- Microphone on flex arm
- Spray hose assembly
- Eyewash assembly
- Utility drawer
- Flammable storage cabinet
- Three side rinse
- End rinse assembly
- Dissection area rinse
- Stainless steel shelving
- Formalin dispensing and/or collection system
- Glove box holder
- Foot pedal faucet w/cover

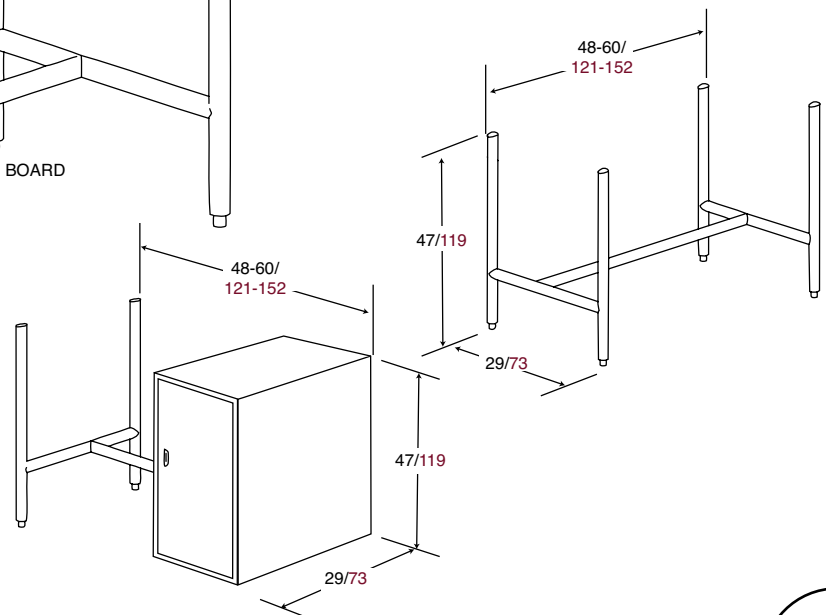

All measurements in inches/centimeters

Options based on available space.

When planning an order, please call us and we will assist you in determining which options to choose.