



MODEL 1036-232
BACKDRAFT DISSECTION
WORKSTATION

CAUTION

• Inspect unit and all components for any loosening that may have occurred during shipping •

CAUTION

• DO NOT USE CLEANERS CONTAINING CHLORINE WHEN CLEANING STAINLESS STEEL •

ATTENTION

Review entire manual before starting assembly

ATTENTION

All images and Drawing in this manual may not represent your model. Refer to your particular project for exact specifications



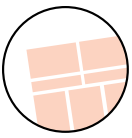

It is important that the information provided in this manual is observed. These instructions should be read carefully and observed fully before installation and initial operation.

WARNING

It is crucial that any work performed on Mortech Manufacturing Inc. manufactured items are carried out exclusively by skilled professionals who have the respective training. Improper use, maintenance, parts and service, or modification to the equipment may cause injury and/or damage. Use and maintain the equipment only for the purpose described in this manual. Use only Mortech Manufacturing Inc. prescribed approved parts and service. Use the equipment only as designed by Mortech Manufacturing Inc.

BLOODBORNE DISEASE NOTICE

To reduce the risk of exposure to bloodborne diseases such as HIV-1 and hepatitis when using the equipment, follow the disinfecting and cleaning instructions in this manual.

RECOMMENDED OPERATING SKILLS AND TRAINING

- SKILLS

Operators using the equipment need:

- A working knowledge of necessary procedures.
- The ability to carry out necessary service procedures.
- A complete understanding of the procedures described in this manual.

- TRAINING

- Read the this manual as prescribed
- Be trained on the use of the equipment.
- Practice with the equipment before using it in regular service.
- Be tested on their understanding of the equipment operation.
- Record their training.

BEFORE USING THE EQUIPMENT

Personnel working with this equipment needs to read this manual. Assemble of the unit following set instructions, and perform any pre-service checks to confirm the units operates properly.

INSPECTING THE UNIT BEFORE USE

Please take time to inspect all shipment prior to signing delivery ticket. If concealed damage is discovered, save the carton and immediately contact carrier agent to initiate claim of damage.

! BE SURE TO CHECK

- Are all components present?
- Do the moving parts operate smoothly?
- Is unit draining properly?
- Are all nuts, bolts, and pins secured in place?
If unit has an issue contact Mortech Manufacturing Inc.

INSTRUCTION FOR HANDLING

Adhere to state and/or local certification and regulations for operation of forklift and/or pallet jack. Cargo is extremely heavy, be sure to have the necessary manpower as well as equipment to successfully unload shipment from transport. We recommend a forklift and/or pallet jack with the capacity to lift up to 2000 lbs. to remove cargo from transport.

The forklift can be used to unload receiving products safely by placing the load on the floor, maneuvering the forklift into position, tilting the mast forward to vertical position so the load will be level, lowering the load, and smoothly backing away without dragging. Once cargo is unloaded, positioning equipment for installation will once again require a forklift. Read all manual and note on installation of the unit before attempting installing.

The pallet jack can be used (with a loading dock and maneuverability on and off the transport vehicle) to unload receiving products safely. Maneuvering the pallet jack into position (in the appropriate position within the pallet), lifting the pallet then driving the pallet jack off the transport and safely into the place of installation.

Range of Environmental Condition

Mortech Manufacturing, Inc. equipment shall be placed in a controlled environment (housing or housed unit) hindering the weathering effects on the installed units. The equipment will have minimal corrosive and eroding factors that can break down the stability and operation of Mortech Manufacturing Inc. equipment. The impact on the equipment by the operator utilizing water or corrosives in the medical procedures can be controlled and responsibility for the cleaning and maintenance placed upon that person. The effects of anthropogenic (man-made) gasses on the environment, such as carbon dioxide (CO₂) that will be omitted from the unit should be minimal.

Due to continuous innovation and product development this installation guide is subject to change without notice.

Please save these instructions for later use.

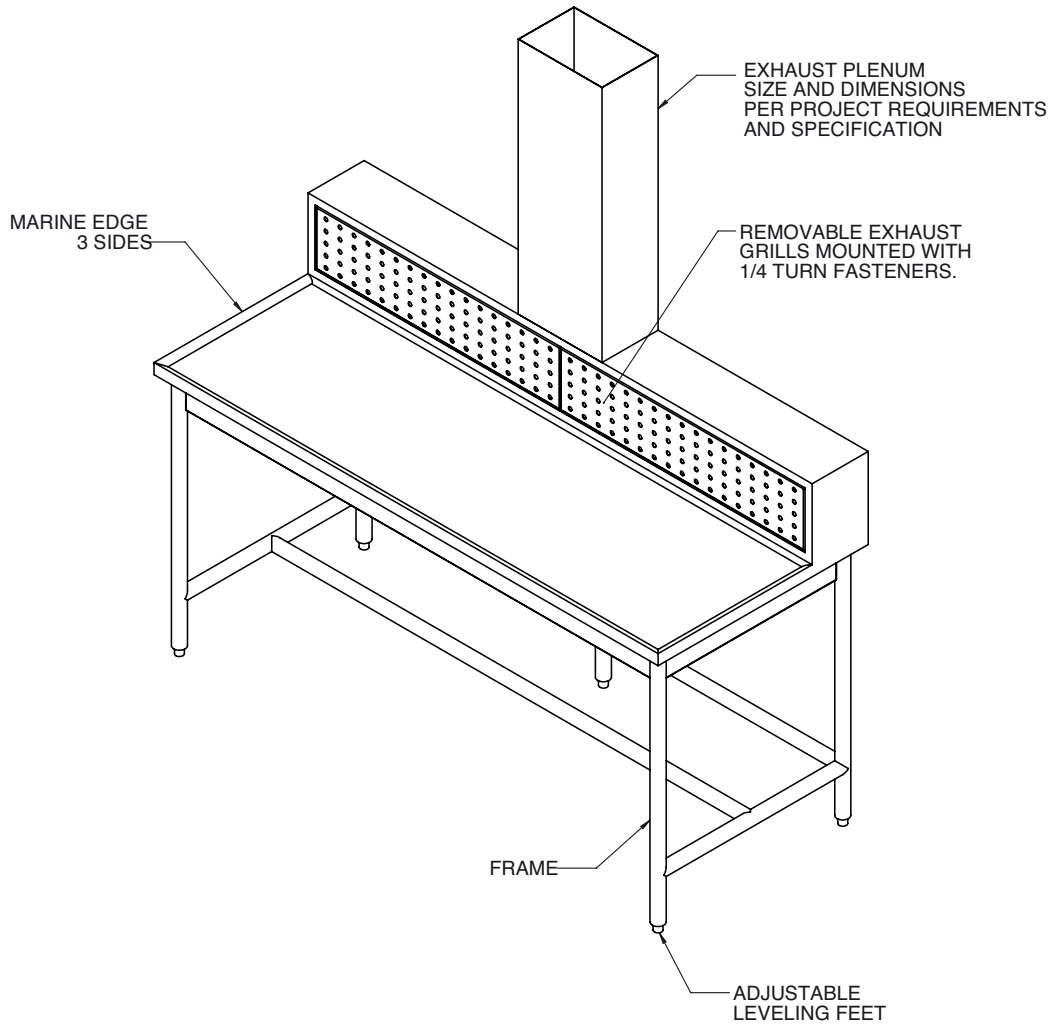

Our backdraft dissection stations are designed to provide an economical vented work area for controlling odors, gases and chemical fumes. We offer a variety of optional features including sinks, storage drawers and cabinets, lab gas fixtures, lighting and enable you to customize stations.

STANDARD DESIGN FEATURES

Width:Per Project requirements
Length:Per Project requirements
Height:Per Project requirements

- All stainless steel construction
- Fabricated from heavy gauge 304 stainless steel with a No. 4 finish with a marine edge
- Manual adjustable damper
- Heliarc-welded seams and joints, ground and polished to match adjoining surfaces

- Stainless steel base frame w/adjustable leveling feet
- Backdraft ventilation provided
- Removable grill held in place with thumb screws
- Duct connection size and quantity based upon length of table

TROUBLESHOOTING

Rust developing

- Check for standing water in rust area
remove standing water
- Check for non stainless metals left on rust area
- Follow rust removal instructions



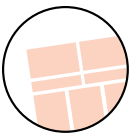

MOUNTING INSTRUCTIONS

Make sure floor is clear of debris and level. Verify all rough ins have been supplied in the proper location and per the project specifications.

1. Use feet levelers to level the table.
2. Place the workstation into final mounting position.
3. Verify what type of support structure has been provided for mounting. Use mounting anchors appropriate for support structure.
4. Drill appropriate size hole for the anchor.
5. Secure the anchors.
6. Repeat along back of unit to secure.



← **STAINLESS STEEL FOOT LEVELERS**

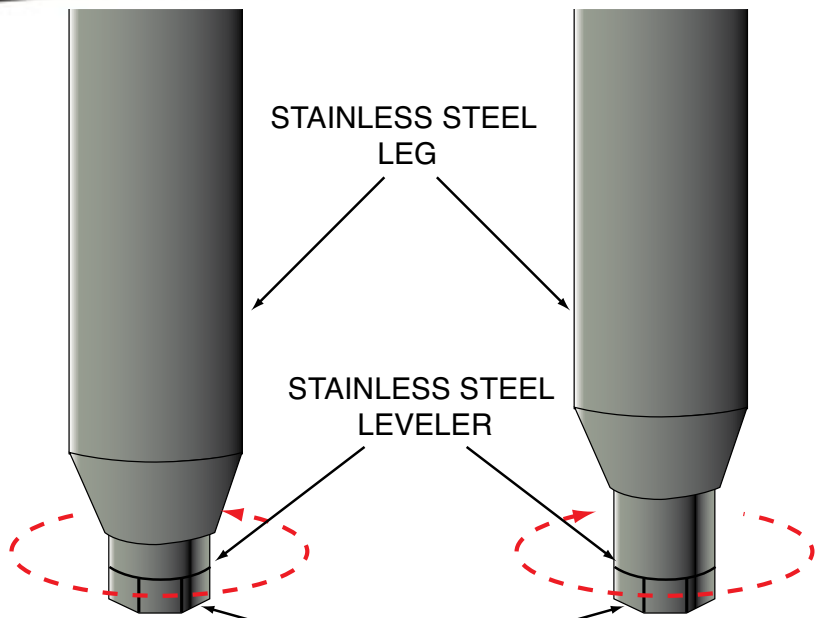

STAINLESS STEEL LEG

STAINLESS STEEL LEVELER

KNOTCHED TO FIT AN ADJUSTABLE WRENCH

ROTATE COUNTER CLOCKWISE TO LOWER THE ADJUSTMENT

ROTATE CLOCKWISE TO RAISE THE ADJUSTMENT

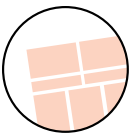

1036-232 Multiple Dissection Workstation

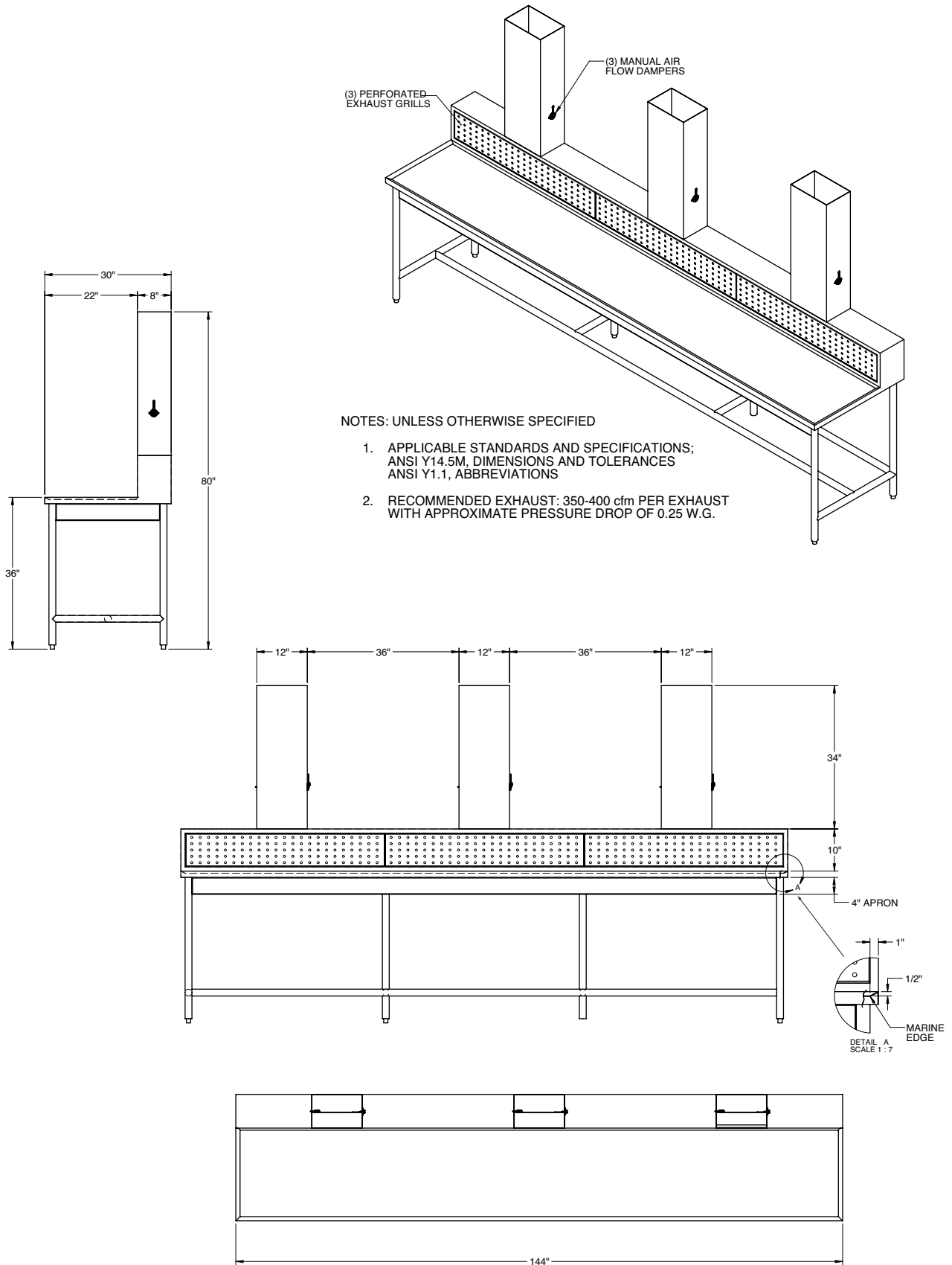

1036-232 Backdraft Dissection Workstation

Project installation

1036-232 Multiple Dissection Workstation with Sink and Hot and Cold Foot Control

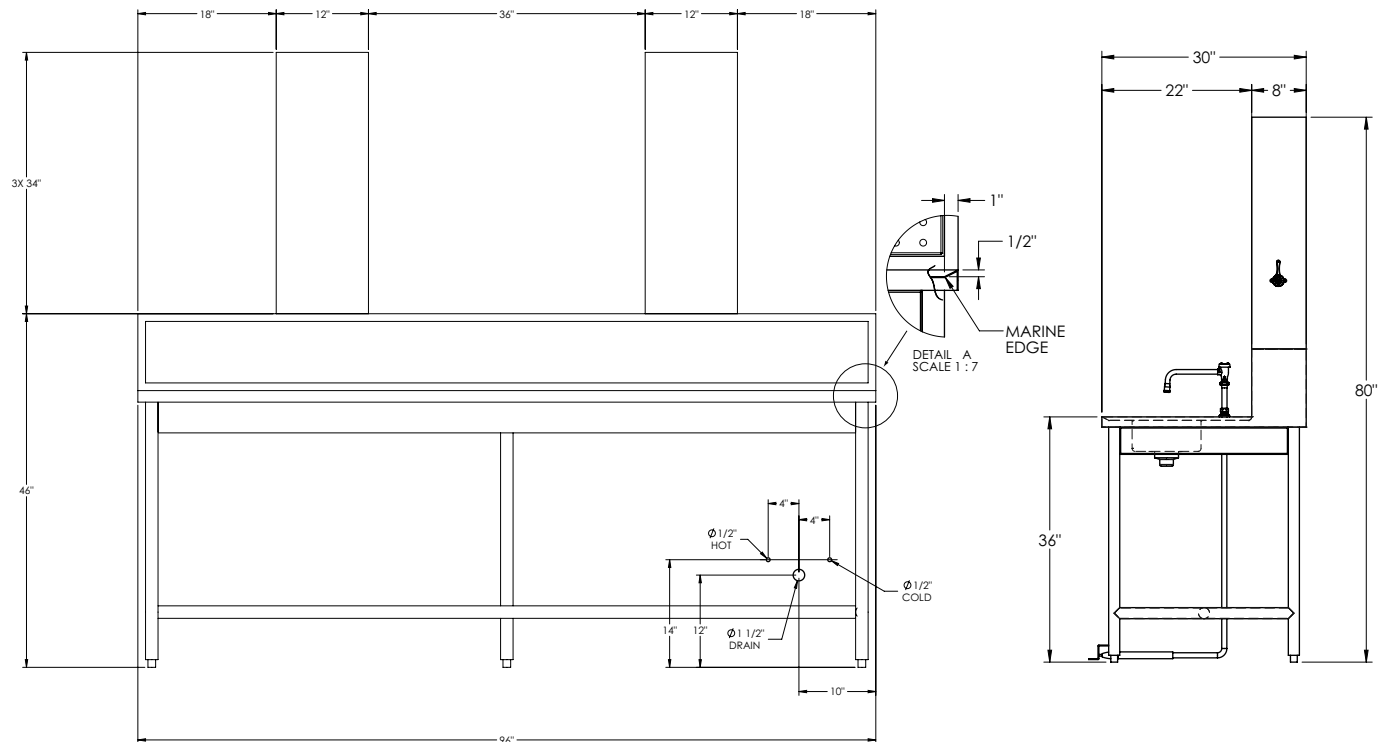
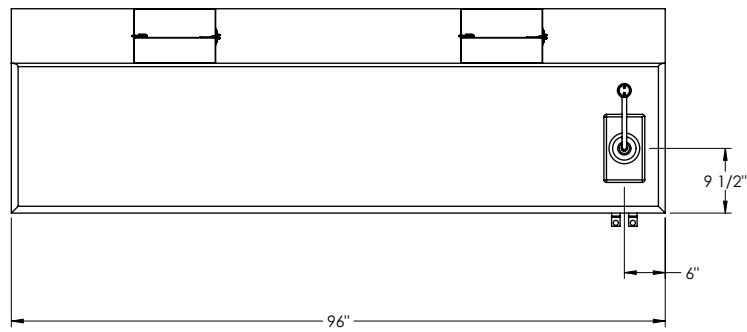
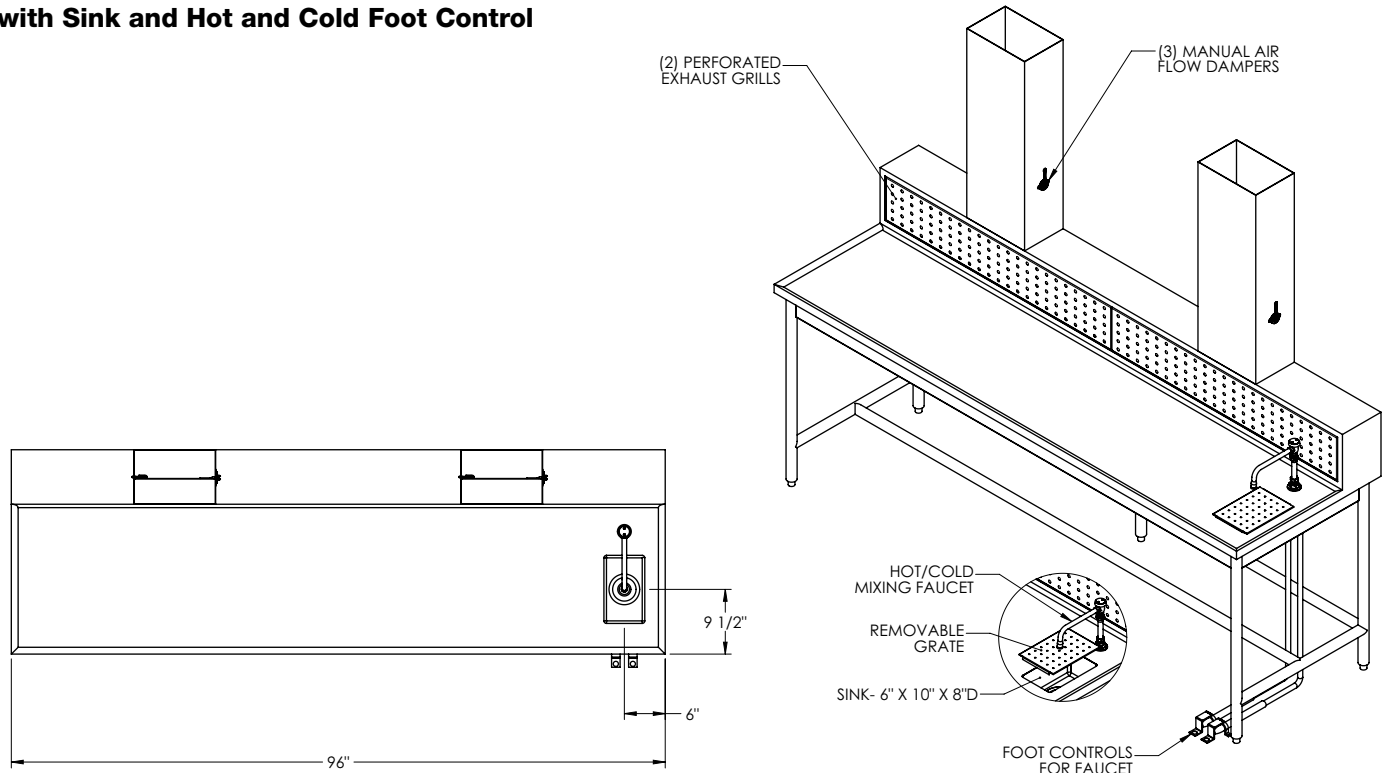

UTILITY REQUIREMENT NOTES:

1. FLUSH LINES CLEAR BEFORE CONNECTING TO STATION.
2. PLUMBER TO PROVIDE SHUT-OFF VALVES FOR WATER CONNECTIONS AND P-TRAP FOR DRAIN.
3. RECOMMENDED EXHAUST: 350-400 cfm PER EXHAUST WITH APPROXIMATE PRESSURE DROP OF 0.25 W.G.



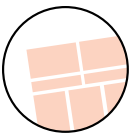

Parts listing

1036-232 Backdraft Dissection Workstation

Removable Exhaust Grill

Exhaust Plenum

Damper Control

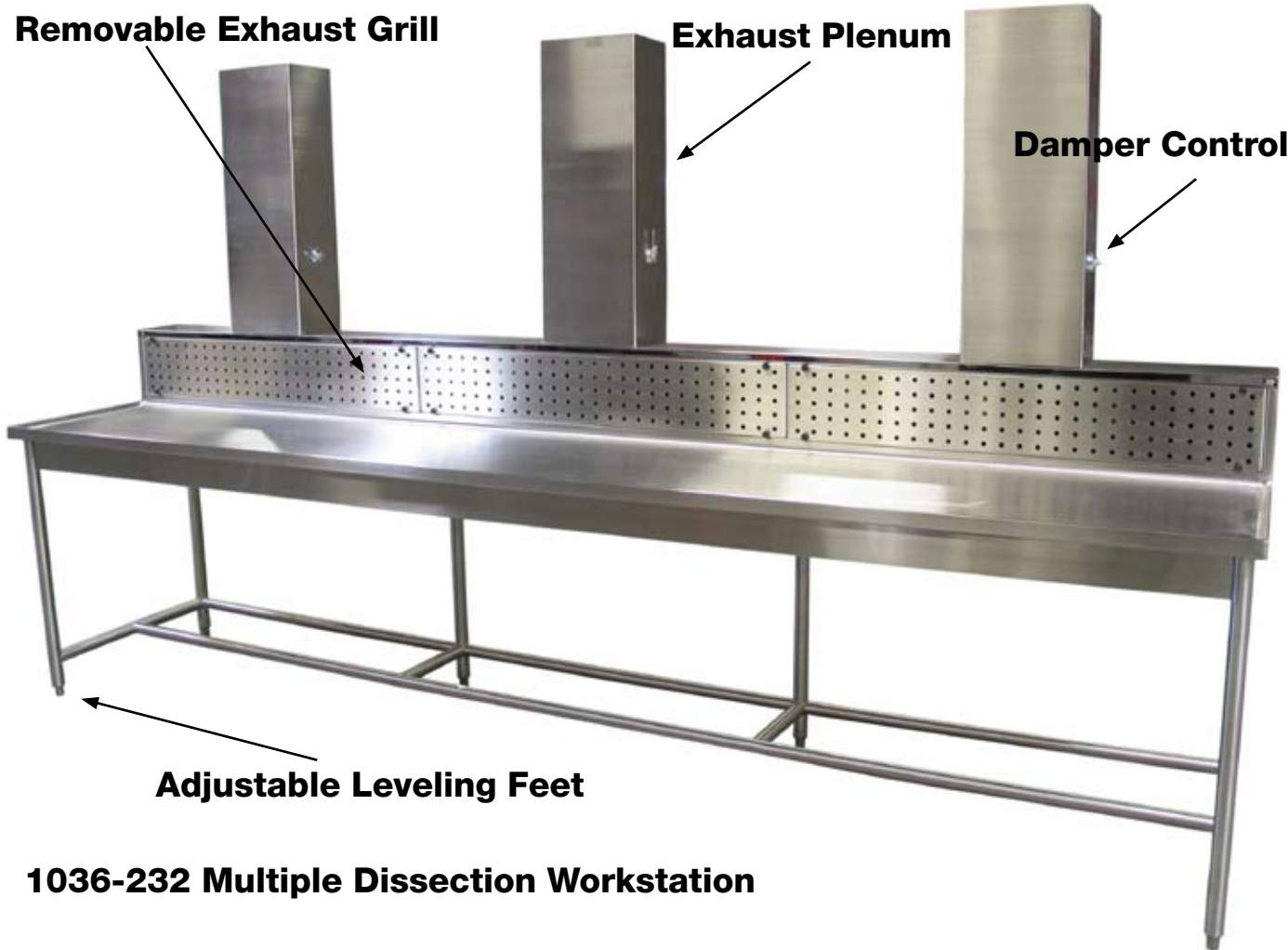

Adjustable Leveling Feet

1036-232 Multiple Dissection Workstation



1036-232 Standard Dissection Workstation

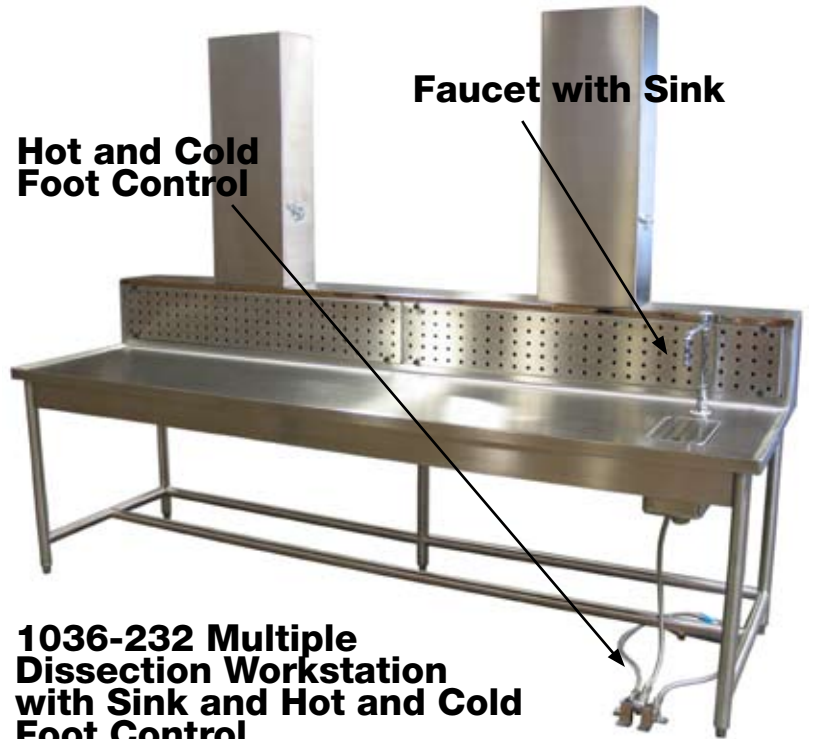

Hot and Cold Foot Control

Faucet with Sink

1036-232 Multiple Dissection Workstation with Sink and Hot and Cold Foot Control

ADJUSTING DAMPER



DAMPER SHOWN IN THE OPEN POSITION ALLOWING UNRESTRICTED AIR FLOW



MOVE THE DAMPER LEVER IN A COUNTER-CLOCKWISE MOTION UNTIL DESIRED AIR-FLOW



LOOSEN THE SECURE WINGNUT TO ADJUST DESIRED AIRFLOW



TIGHTEN THE SECURE WINGNUT TO SECURE DAMPER IN POSITION

EXHAUST DUCT CONNECTION INSTRUCTIONS

Step 1. Connect sink duct to building duct.



Remove the thumb screw to get inside the ventilation chamber.



Remove all (4) thumb screw and remove the grid cover.



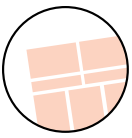

MAINTENANCE INSTRUCTIONS

The unit requires regular maintenance and follow the manufactures directions.

DISINFECTING AND CLEANING

Clean all surfaces of the stainless steel with a hard surface disinfectant/cleaner such as Sheila Shine® or SaniZene®. Follow instructions on container.

DISINFECTING, CLEANING COMPONENTS & ACCESSORIES

Hand wash with disinfecting soap and warm water. Rinse well with clear water and dry with a towel. (Clean on a regular basis to prolong work life).

WARNING

Improper maintenance can cause injury. Maintain only as prescribed in this manual. Overall, it is very simple to maintain. If you use for its intended purpose, it will provide many years of reliable service.

CARE OF STAINLESS STEEL

Stainless steel products have a directional #4 brushed finish. This finish is produced using a very fine abrasive cloth. Dragging heavy equipment across the stainless steel surfaces will cause noticeable scratching. Pitting/corrosion can occur when carbon steel products are allowed to remain in contact with the stainless steel in the presence of moisture. (Examples- Steel Wool pads left in the bottom of the sink). Stainless steel can be damaged by exposure to acids.

TYPES OF SURFACE CONTAMINANTS

- **Dirt** - Consist of accumulated dust and a variety of contaminates. Warm water with or without a gentle detergent is sufficient. Next in order are mild non-abrasive powders such as typical household cleaners. These can be used with warm water, bristle brushes, sponges, or cleaning cloths. (Do not use carbon steel brushes or steel wool they may leave particles embedded on the surface which can lead to RUSTING.) For more aggressive cleaning, a small amount of vinegar can be added to the scouring powder. When water contains mineral solids, which leave water spots, it is advisable to wipe the surface completely with dry towels.
- **Fingerprints and Stains** - Fingerprints and mild stains resulting from normal use are the most common surface contaminates. This affect the appearance and seldom have an effect on corrosion resistance. They can be removed with a glass cleaner or by gentle rubbing with a paste of soda ash (sodium carbonate) and water applied with a soft rag. Followed by a thorough warm water rinse and towel dry.
- **Shop Oil and Grease** - These soils may be corrosive and may not allow the surface to maintain passivity, and so removal is a necessity. Soap or detergent and water may be used or a combination of detergent and water plus a solvent.

TYPES OF CLEANERS AND METHODS

- **General Precautions**
Avoid using abrasive cleaners unless absolutely necessary. A "soft abrasive," such as pumice, should be used. Many cleaners contain corrosive ingredients, rinse with clean water.
- **Clean Water and Wipe** - A soft cloth and clean warm water should always be the first choice for mild stains, loose dirt and soils. A final rinse with clean water and a dry wipe will eliminate the possibility of water stains.
- **Solvent Cleaning** - Organic solvents can be used to remove fresh fingerprints, oils and greases that have not had time to oxidize or decompose. The preferred solvent is one that does not contain chlorine, such as acetone, methyl alcohol, and mineral spirits.

EFFECTIVE CLEANING METHODS

Commercial Cleaners - Many commercial cleaners compounded from phosphates, synthetic detergents, and alkalis are available for the cleaning of severely soiled or stained stainless surfaces. When used with a variety of cleaning methods, these cleaners can safely provide effective cleaning.

SCRATCH REPAIR

Surface scratches can be repaired using the following technique. Depending on the severity of the scratch, it may be possible to completely remove it. Sand the scratch using 120 grit emery cloth or paper and firm pressure. Always sand in the direction of the grain. Avoid the natural tendency to sand in an arc, instead sand in a perfectly straight line. Sand until the scratch is gone. Polish using 3M Scotch Brite pads - Very Fine Grade. Use the same motions as with sanding. Polish until the original finish is restored. Wash and wipe the surface completely with dry towels.

RUST REMOVAL

Rust can be repaired using the following technique. Sand the scratch using 120 grit emery cloth or paper and firm pressure. Always sand in the direction of the grain. Avoid the natural tendency to sand in an arc, instead sand in a perfectly straight line. Sand until the rust is gone. Polish using 3M Scotch Brite pads - Very Fine Grade. Use the same motions as with sanding. Polish until the original finish is restored. Wash and wipe the surface completely with dry towels.

5 Stainless Steel Mistakes NOT to Make When Cleaning

- 1. Do not use abrasive cleaners that will scratch the surface.** Depending on the surface finish of your stainless steel, abrasive cleaners can cause scratching. A dull finish, probably will not show scratching as much as mirror or highly polished finishes. Test the cleaner in a hidden spot. It's also a good idea to work from the least risky type (water) of cleaning to the heavy duty stuff.
- 2. Do not forget to rinse.** Gritty or dirty water can leave a residue on your finish. It can also stain or pit the surface of your stainless steel. Rinse completely. Residue from cleaning solutions left on a stainless steel surface can stain or damage finish.
- 3. DO NOT USE CLEANERS CONTAINING CHLORINE.** While it may be second nature to bleach everything, stainless steel and chlorine do not mix. Stay away from the bleach when you clean stainless steel. Be aware that bleach can be included in different types of cleaners. If you accidentally get a cleaner on your stainless steel you'll need to rinse it off and quickly.
- 4. DO NOT USE STEEL WOOL OR STAINLESS BRUSH** These products leave little particles in the surface of the steel and inevitably these particles begin rusting and staining the surface of the steel. They also can excessively scratch the surface of your stainless steel. *Stay completely away from steel wool and steel brushes.*
- 5. Do not assume it's the cleaner.** If you do have some spotting or staining, and you've followed all of the rules, it may not be the stainless steel cleaner. Water, especially hard water, can leave spotting and staining on stainless steel surfaces. Towel dry after rinsing can end the problem. Sometimes, even water is an enemy to stainless steel.

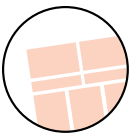

WARRANTY

Mortech Manufacturing, Inc. warrants all fabrications to be free of defects due to its own workmanship and materials.

Repair and/or replacement of materials furnished that may develop such defects, will be warranted for a period of one year from the date of shipment.

Items not manufactured by Mortech Manufacturing, Inc. will receive the manufacturer's warranty.

PARTS AND SERVICE

Customer relations and product support are important aspects of Mortech Manufacturing, Inc. For assistance with this or any of our fine products please contact us below:

Mortech Manufacturing, Inc.
411 North Aerojet Avenue
Azusa, CA 91702
TEL (626) 334-1471
FAX (626) 334-1704
www.mortechmfg.com
info@mortechmfg.com

© COPYRIGHT MORTECH MANUFACTURING, INC., ALL RIGHTS RESERVED.

CAUTION
• Inspect unit and all components for any loosening that may have occurred during shipping •

ATTENTION
All images and Drawing in this manual may not represent your model. Refer to your particular project for exact specifications

DISCLAIMER

This manual contains general instructions for the use, operation, and care of this product. The instructions are not all inclusive. Safe and proper use of this product is solely at the discretion of the user. Safety information is included as a service to the user. All other safety measures taken by the user should be within and under consideration of applicable regulations. It is recommended that training on the proper use of this product be provided before using this product in and actual situation.

Retain this manual for future reference. Include it with the product in the event of transfer to new users. Additional free copies are available upon request from Customer Relations.

Mortech Manufacturing, Inc. has made every effort to ensure that this Manual is accurate; Mortech Manufacturing, Inc. abdicate liability for any inaccuracies or omissions that may have occurred.

Information in this Manual is subject to change without notice and does not represent a commitment on the part of Mortech Manufacturing, Inc. Mortech Manufacturing, Inc. assumes no responsibility for any inaccuracies that may be contained in this Manual. Mortech Manufacturing, Inc. makes no commitment to update or keep current the information in this Manual, and reserves the right to make improvements to this Manual and/or to the products described in this Manual, at any time without notice.

If you find information in this manual that is incorrect, misleading, or incomplete, we would appreciate your comments and suggestions.

PROPRIETARY NOTICE

The information in this manual is the property of Mortech Manufacturing, Inc. Mortech Manufacturing, Inc. reserves all patent rights, proprietary design rights, manufacturing rights, reproductions rights, and sales use rights thereto, and to any article disclosed therein except to the extent those rights are expressly granted to others or where not applicable to vendor proprietary parts.

