



MODEL 1036-8
WALL MOUNTED AUTOPSY STATION
RIGHT DISSECTING

CAUTION

- Inspect unit and all components for any loosening that may have occurred during shipping •

ATTENTION

Review entire manual before starting assembly

ATTENTION

All images and Drawing in this manual may not represent your model. Refer to your particular project for exact specifications

CAUTION

- DO NOT USE CLEANERS CONTAINING CHLORINE WHEN CLEANING STAINLESS STEEL •

WARNING

Biohazard Label is place on the equipment signifying the potentially infectiousness due to the samples or reagents



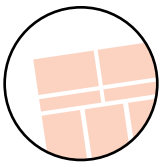

It is important that the information provided in this manual is observed. These instructions should be read carefully and observed fully before installation and initial operation.

WARNING

It is crucial that any work performed on Mortech Mfg. Inc. manufactured items are carried out exclusively by skilled professionals who have the respective training. Improper use, maintenance, parts and service, or modification to the equipment may cause injury and/or damage. Use and maintain the equipment only for the purpose described in this manual. Use only prescribed approved parts and service. Use the equipment only as designed by Mortech mfg. Inc.

BLOODBORNE DISEASE NOTICE

To reduce the risk of exposure to bloodborne diseases such as HIV-1 and hepatitis when using the equipment, follow the disinfecting and cleaning instructions in this manual.

OPERATING SKILLS AND TRAINING SKILLS

Operators using the equipment needs

- A working knowledge of necessary procedures.
- The ability to carry out necessary service procedures.
- A complete understanding of the procedures described in this manual.

TRAINING

- Be trained on the use of the equipment.
- Read the manual
- Practice with the equipment before using it in regular service.
- Be tested on their understanding of the equipment operation.
- Record their training.

BEFORE USING THE UNIT

Personnel working with this unit needs to read this manual. Assemble of the unit following instructions, and perform any pre-service checks to confirm the units operates properly.

INSPECTING THE UNIT BEFORE USE

Please take time to inspect all shipment prior to signing delivery ticket. If concealed damage is discovered, save the carton and immediately contact carrier agent to initiate claim of damage.

BE SURE TO CHECK

- Are all components present?
- Do the moving parts operate smoothly?
- Is unit draining properly?
- Are all nuts, bolts, and pins secured in place?
If unit has an issue contact customer relations.

INSTRUCTION FOR HANDLING

Adhere to state and/or local certification and regulations for operation of forklift and/or pallet jack. Cargo is extremely heavy, be sure to have the necessary manpower as well as equipment to successfully unload shipment from truck. We recommend a forklift and/or pallet jack with the capacity to lift up to 2000 lbs. to remove cargo from truck.

The forklift can be used to unload receiving products safely by placing the load on the floor, maneuvering the forklift into position, tilting the mast forward to vertical position so the load will be level, lowering the load, and smoothly backing away without dragging. Once cargo is unloaded, positioning unit for installation will once again require a forklift. Read all manual and note on installation of the unit before installing.

The pallet jack can be used (with a loading dock and maneuverability on and off the transport vehicle) to unload receiving products safely. Maneuvering the pallet jack into position (in the appropriate position within the pallet), lifting the pallet then driving the pallet jack off the truck and safely into the place of installation.

Range of Environmental Condition

Mortech Mfg. Inc. equipment shall be placed in a controlled environment (housing or housed unit) hindering the weathering effects on the installed units. The units will have minimal corrosive and eroding factors that can break down the stability and operation of Mortech's equipment. The impact on the unit by the operator utilizing water or corrosives in the medical procedures can be controlled and responsibility for the cleaning and maintenance placed upon that person. The effects of anthropogenic (man-made) gasses on the environment, such as carbon dioxide (CO₂) that will be omitted from the unit should be minimal.

Due to continuous innovation and product development this installation guide is subject to change without notice.

Please save these instructions for later use.

DUCT FLANGE

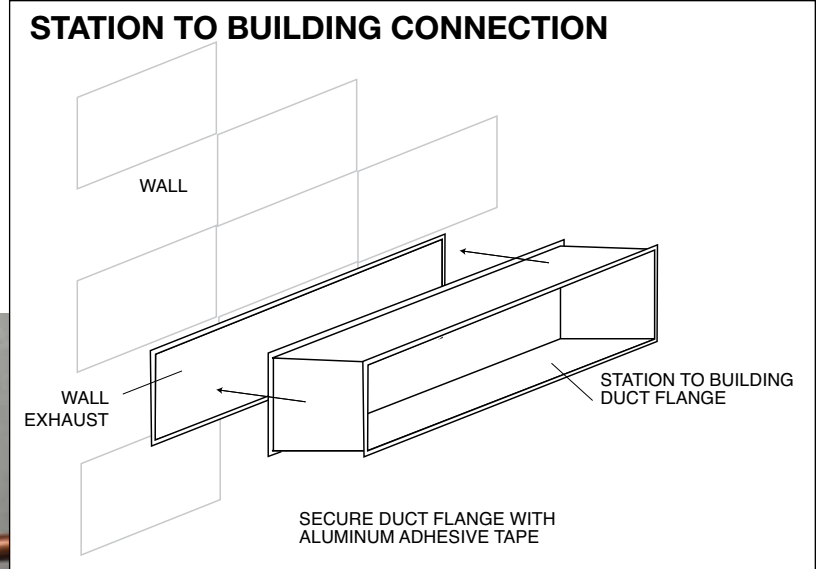

BACK OF VENT OPENING



**DUCT FLANGE-
ATTACHED TO THE
SINK STATION.**

**TO INSTALL:
CENTER DUCT FLANGE
OVER OPENING. NOTCH IF
NECESSARY FOR PLUMBING.
SEAL WITH ALUMINUM TAPE.**

**PLACE AT LEAST A 1/2"
MEDIUM DENSITY FOAM
GASKET BETWEEN THE UNIT
AND THE BUILDING**



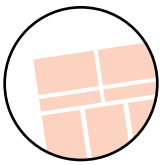

EXHAUST DUCT CONNECTION

INSTRUCTIONS

See Specific Project Drawings for Exhaust Duct Sizes and Locations

UNEXPOSED DUCT CONNECTION

1. HVAC contractor to provide exhaust openings at sizes and locations per your project requirements. Exhaust opening to be flush with finished wall surface. Station is provided with exhaust plenum to fill gap between grill front and building wall opening.

Plenum can be sealed by removing front grill.

(FIGURE - J)

2. Typical Exhaust requirement is 400 CFM at 0.25 w.g.
See your project requirements for specifics.

EXPOSED DUCT CONNECTION

1. HVAC contractor to provide duct work from building to top duct connections on station. Duct material is per project requirements. (FIGURE - K)

2. Typical Exhaust requirement is 400 CFM at 0.25 w.g.
See your project requirements for specifics.

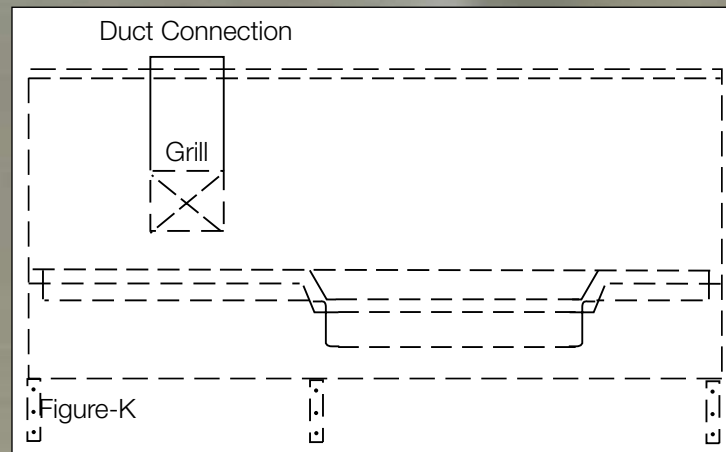
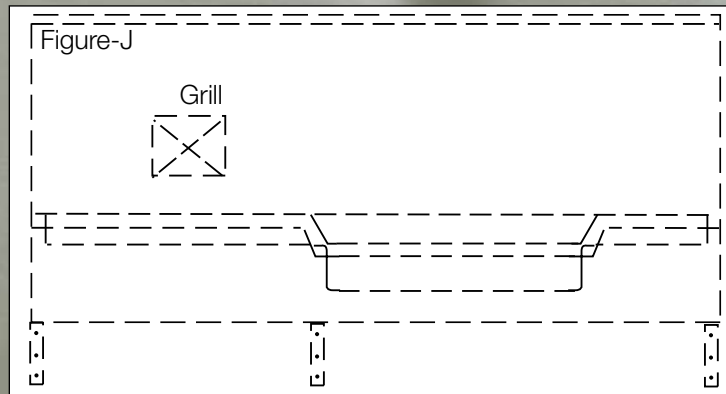

**TO REMOVE GRILL
REMOVE SCREWS**



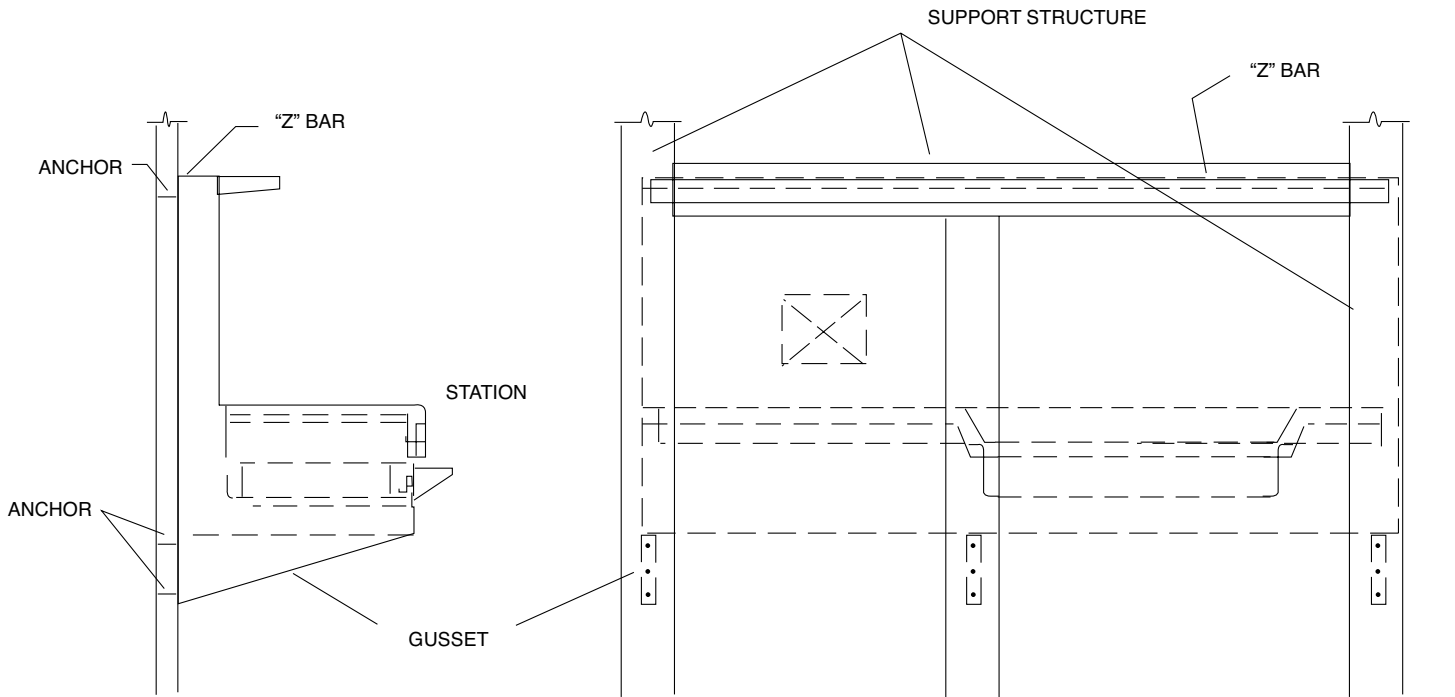

MOUNTING INSTRUCTIONS

Step 1. Verify all utility rough-ins have been supplied in the proper location and per the project specifications. Drawings from Mortech for utilities is provided with the submittal packet information. Utilities can include: water lines, electrical, etc.

Step 2. (Refer to Figure-A) Verify what type of support structure has been provided for mounting. Use mounting anchors appropriate for support structure.

Step 3. Verify mounting height for "z" bar mounting bracket. The "z" bar mounting bracket is supplied with each station from Mortech. Drawings are provided with the submittal packet showing the mounting height. Mount "z" bracket level with appropriate anchor for the backing support provided. The "z" bar is shorter than the overall length of the unit so you must center the "z" bar relative to the center of the station when mounted. Lengths of stations vary per project so you must reference your submittal information for the station length provided.

Step 4. Some stations are large and heavy so it is best to use a mechanical lift to maneuver the station into position. Make sure the unit is resting level on the fork arms. Sometimes a fork extension will be necessary. Raise the unit position and insert the flange of the station into the "z" bar mounting bracket. Lower into position. The unit will fully rest

on the "z" bar. Then raise slightly to take the pressure off.

Step 5. While the lift is still holding the station in position, install the lower anchor at each gusset location. You should install at least (2) anchors per gusset. Gussets are located at each end of the station and (1) or (2) in the center of the unit. Use anchors per above recommendations for type of support structure.

Step 6. The station is now properly anchored to the wall and the lift may be released.

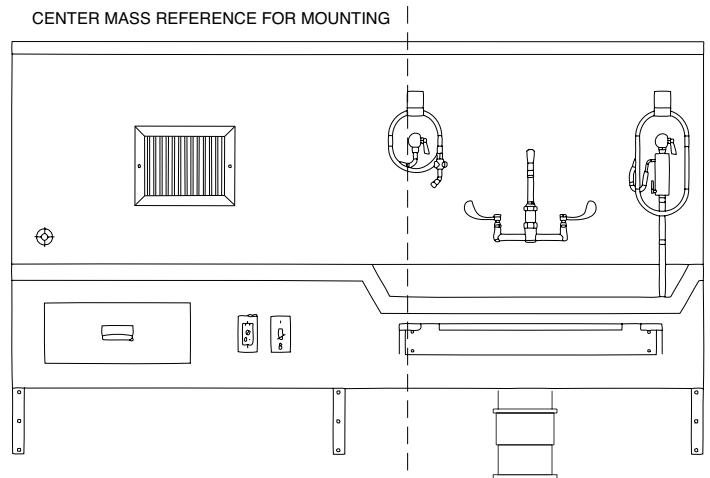

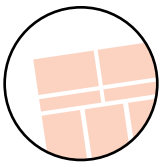

WATTS 009 REDUCED PRESSURE ASSEMBLY
Located underneath the unit.

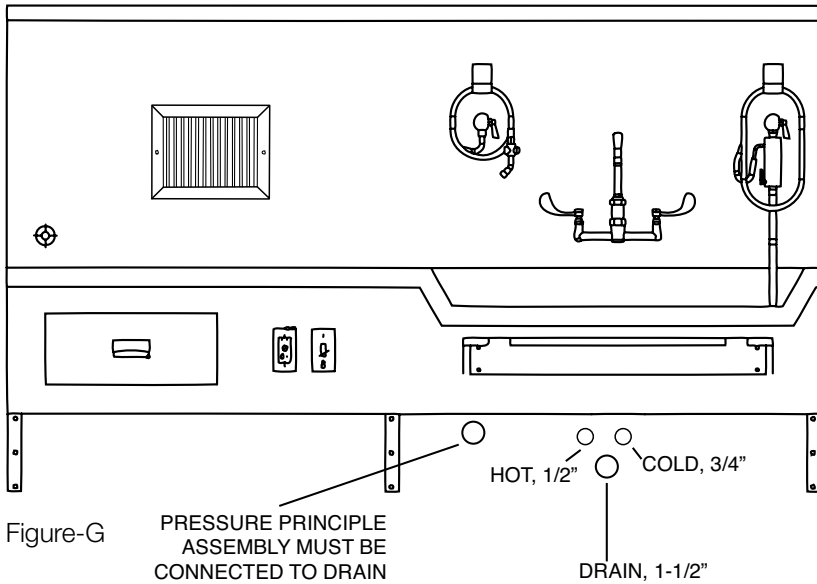

PLUMBING CONNECTION INSTRUCTIONS

STEP 1: (Refer to Figure-G) Flush out all water lines prior to connection. Debris may be in the lines from construction process. Install shut off valves on each water line. Lines are clearly marked RED for hot and BLUE for cold. (Refer to Figure-G1) The station is provided with a single point connection for hot and cold water. A typical flex line can be used for connection.

Step 2: Connect drain line to sink basin or disposal unit, depending on the option provided. (Refer to Figure-H) See disposal manufacturers manual for more information

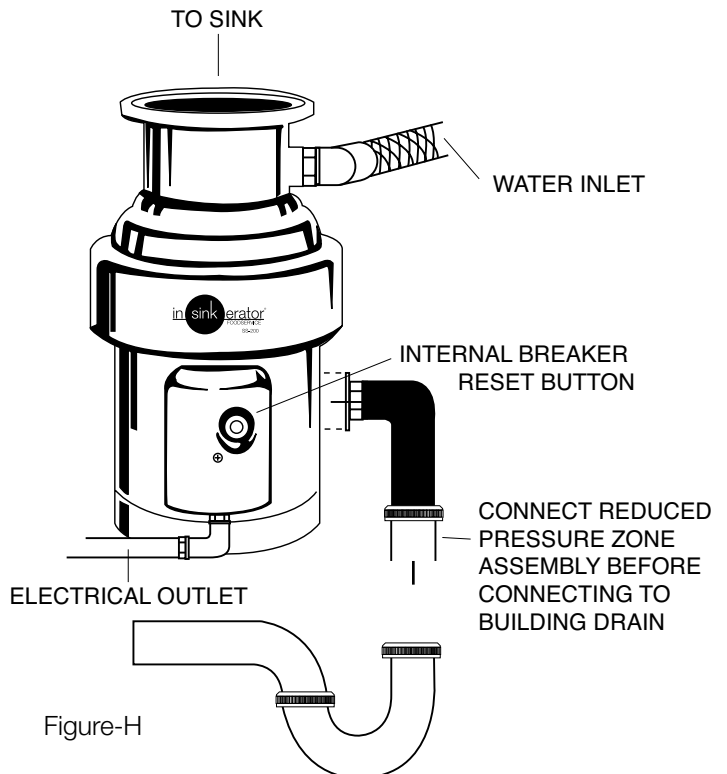
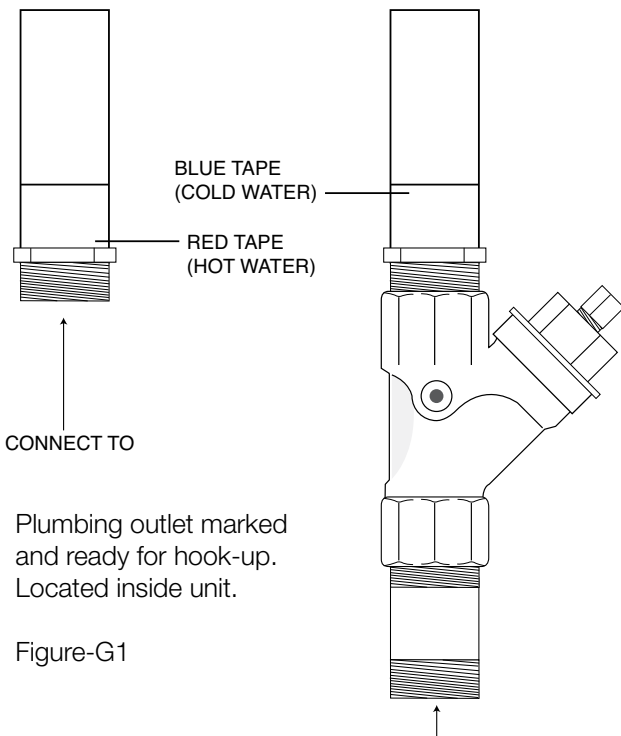

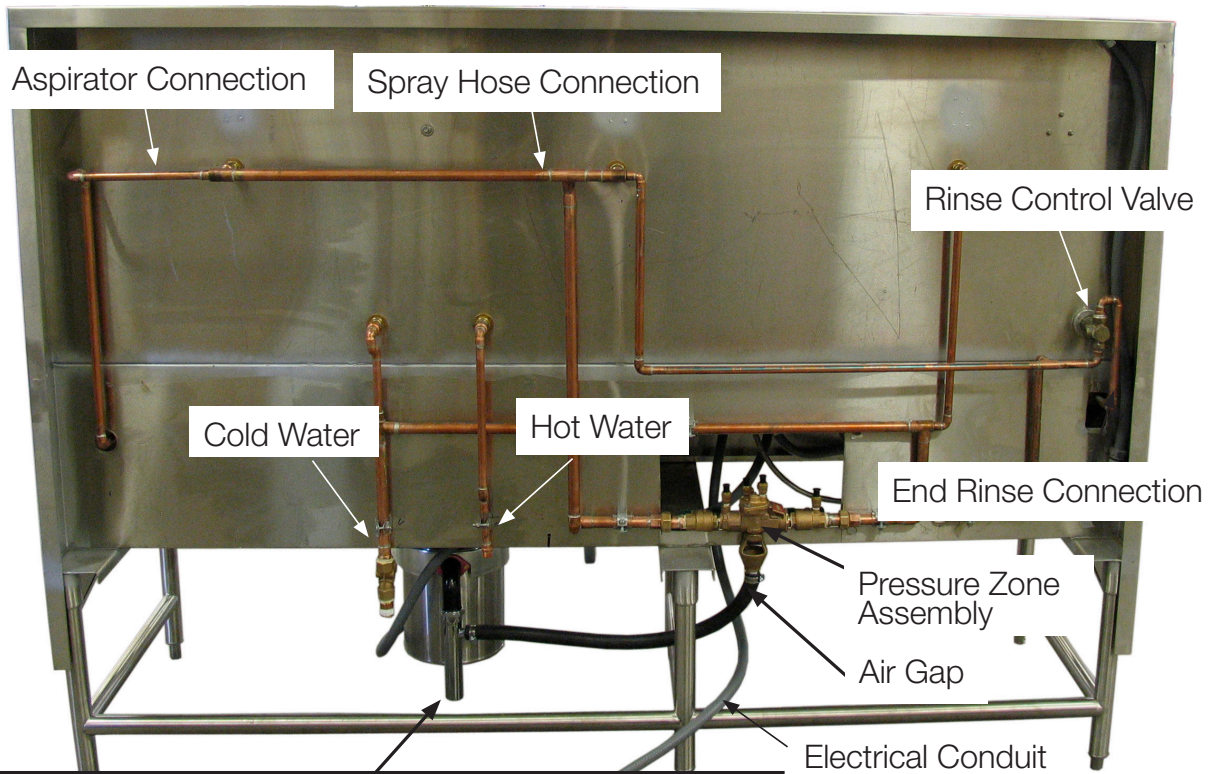

Connect to Reduced Pressure Zone Assembly and then connect to building drain.

SAMPLE CONNECTION TO BUILDING

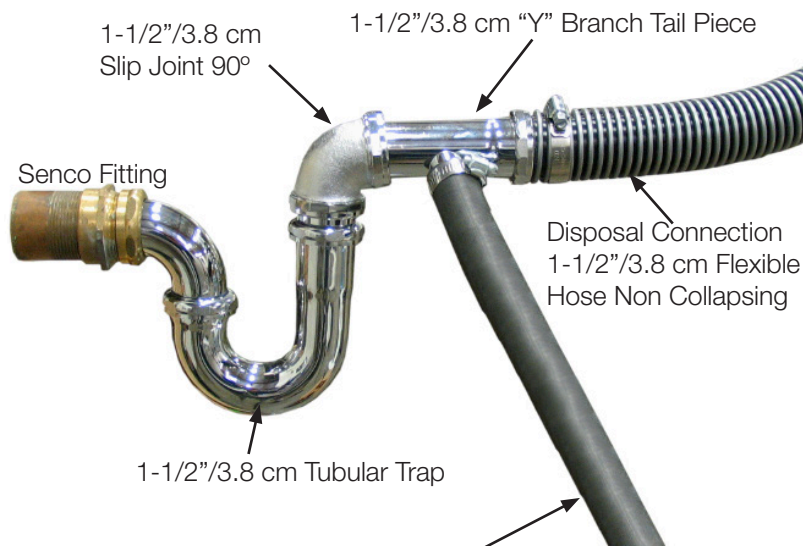

Connect to Reduced Pressure Zone Assembly 7/8"/2.2 cm Dishwasher Hose

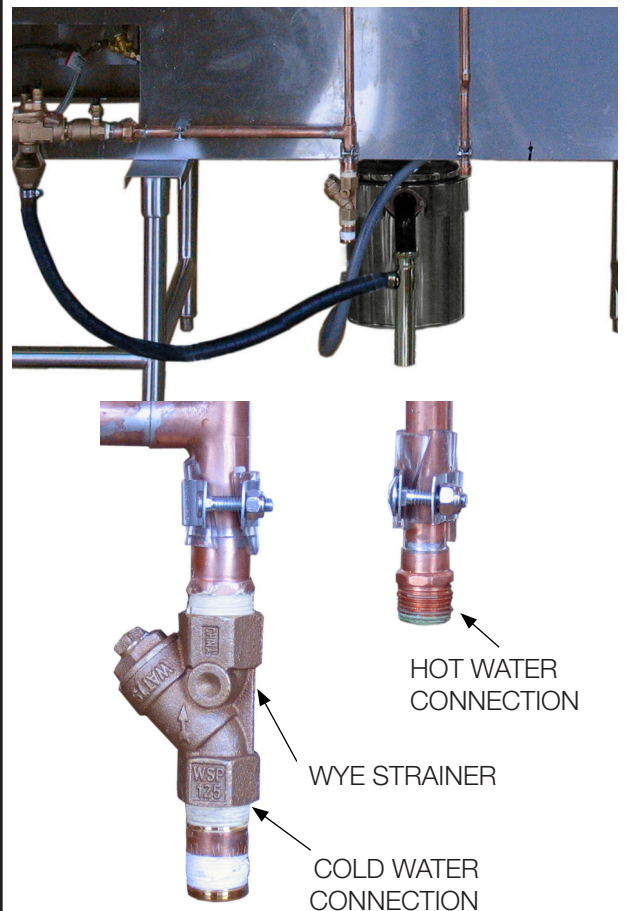

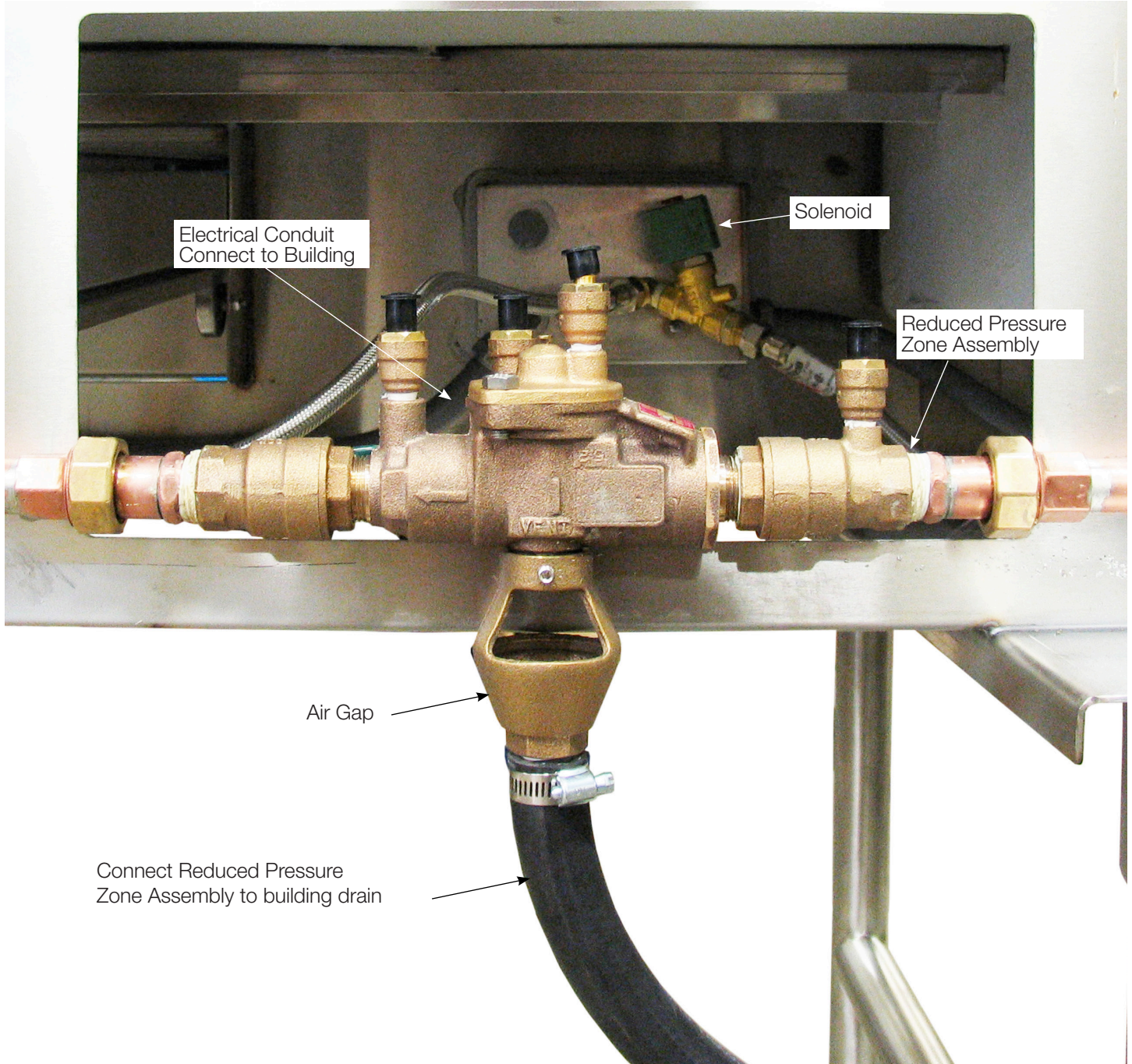

TROUBLESHOOTING

Mixing faucet leaking

- Contact plumber to diagnose problem
- Replace faucet gasket seals

Sink not draining

- Check for debris in sink area
- Contact plumber to diagnose and clear drain if problem persists

Rust developing

- Check for standing water in rust area
remove standing water
- Check for non stainless metals left on rust area
- Follow rust removal instructions

Aspirator not functioning

- Check for adequate water pressure min. -60 lbs. psi
- Check for proper water flow through the unit
4 gallons per minute
- If above two are adequate, disassemble unit and
check for debris causing a clog in the unit.
- Call mortech customer service if problem persists

Disposal not functioning

- See troubleshooting in Manufacturer
Literature provided

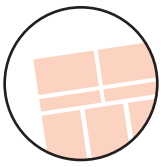

1036-8 Wall Mount Autopsy Station, Right Sink
~120VAC/60hz/1ph (15A Circuit-Disposer, 15A Circuit-GFCI)
Main Power Disconnect To Be Recommended or Supplied:

15A Circuit-Disposer consist of
Solenoids - .05A
Disposer Switch - 15A
Disposer units - (.5 hp, 8.4A)
(.75 hp, 10.0A)
(1 hp, 11.6A)

ELECTRICAL CONNECTION INSTRUCTIONS

1: (Refer to Figure-1 for electrical wiring within the conduit) Connect electrical lines from station to building. Units are provided with watertight conduit lines for connection.

2. A waterproof load center (if requested, optional) with 2 circuit breaker disconnect with a 15A fuse (15A Circuit-Disposer) and 15A fuse (15A Circuit-GFCI) will be attached to the unit itself. Then connected to the point of connection provided on installation site.

15A Circuit-GFCI consist of
GFCI - 20A
Duplex Receptacle - 20A
LED Lights - .31A
Formalin Foot Switch - 10A
Formalin Motor - 6.4A
Elevating Switch/System - 6A

Figure-1

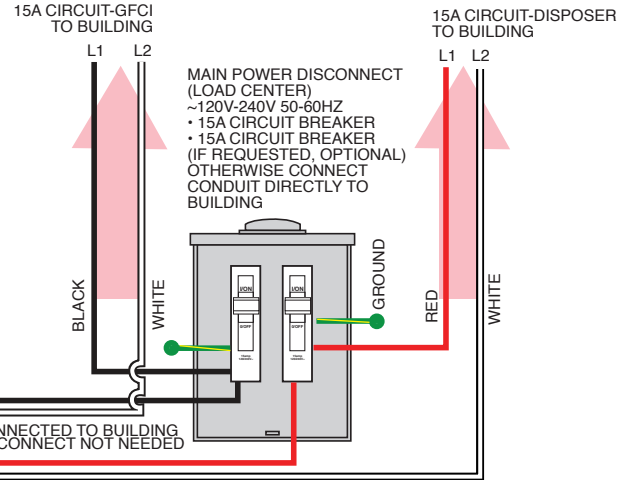
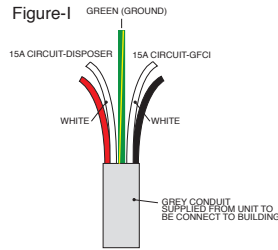
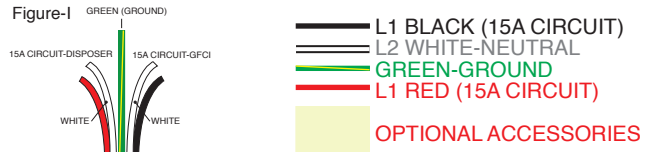

ATTENTION

All images and Drawing in this manual may not represent your model. Refer to your particular project for exact specifications. For general connections, this visual will assist you in identifying parts and connection.

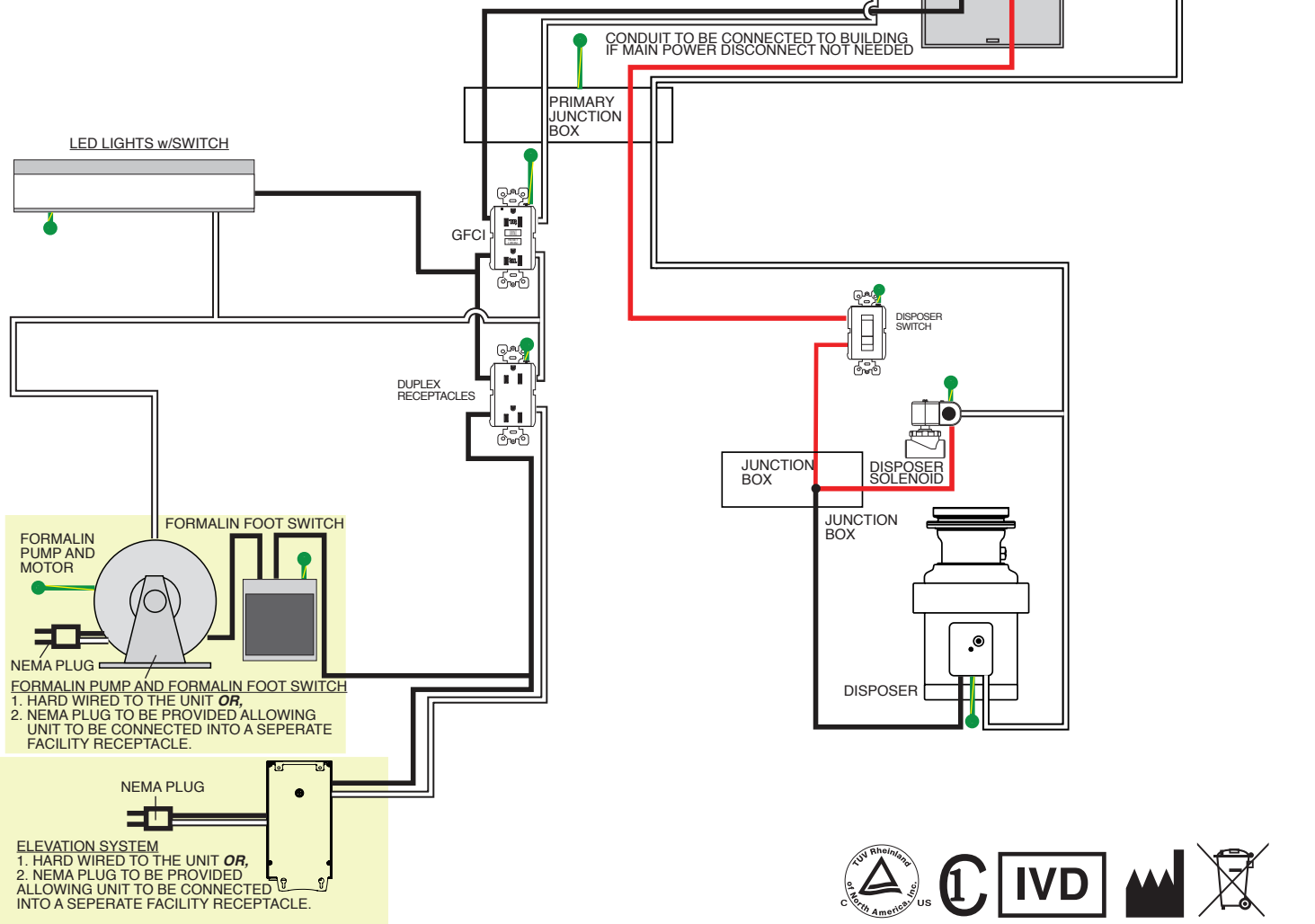

FORMALIN PUMP AND MOTOR
FORMALIN FOOT SWITCH
NEMA PLUG
FORMALIN PUMP AND FORMALIN FOOT SWITCH
1. HARD WIRED TO THE UNIT OR,
2. NEMA PLUG TO BE PROVIDED ALLOWING UNIT TO BE CONNECTED INTO A SEPERATE FACILITY RECEPTACLE.

ELEVATION SYSTEM
NEMA PLUG
ELEVATION SYSTEM
1. HARD WIRED TO THE UNIT OR,
2. NEMA PLUG TO BE PROVIDED ALLOWING UNIT TO BE CONNECTED INTO A SEPERATE FACILITY RECEPTACLE.



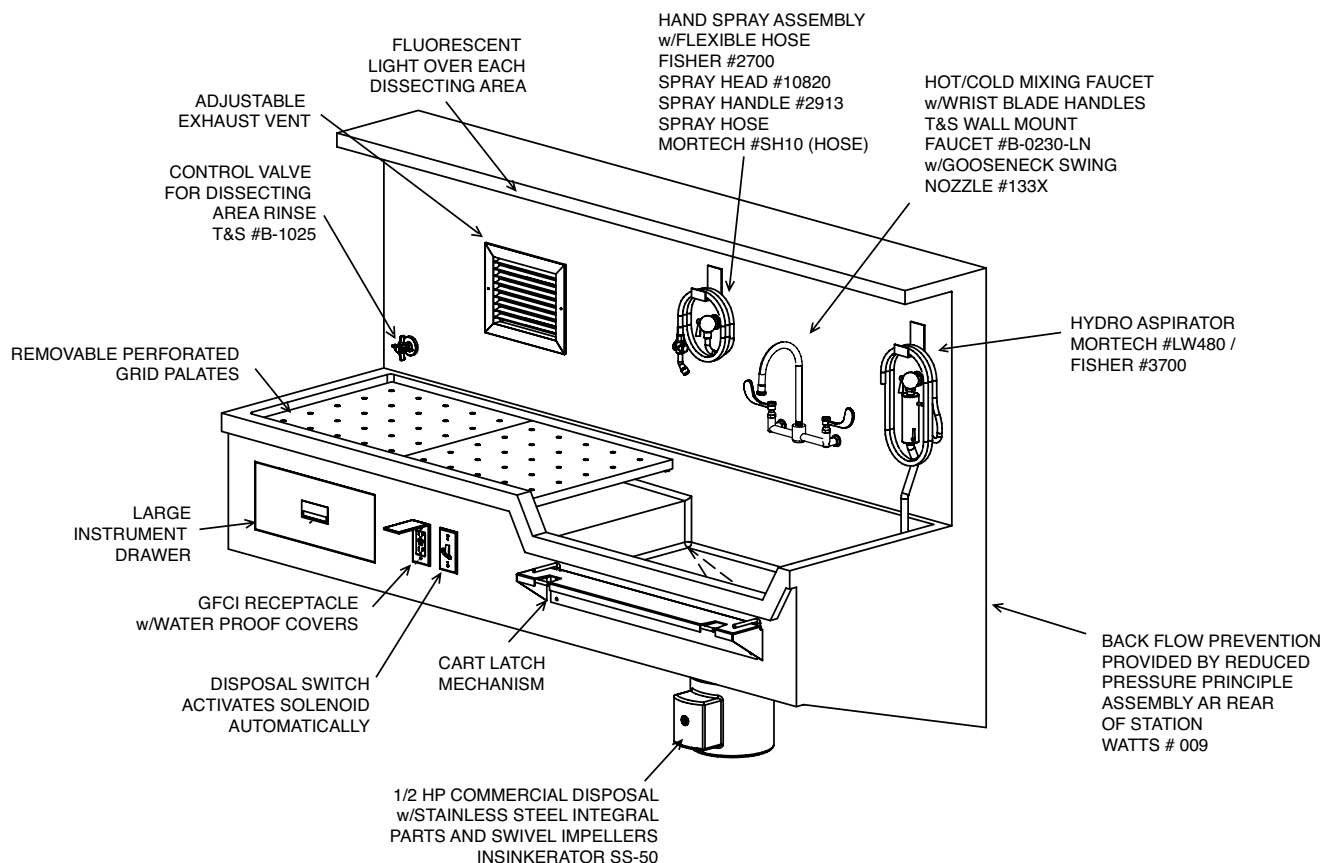

TROUBLESHOOTING

Mixing faucet leaking

- Contact plumber to diagnose problem
- Replace faucet gasket seals

Sink not draining

- Check for debris in sink area
- Contact plumber to diagnose and clear drain if problem persists

Rust developing

- Check for standing water in rust area remove standing water
- Check for non stainless metals left on rust area
- Follow rust removal instructions

Aspirator not functioning

- Check for adequate water pressure min. -60 lbs. psi
- Check for proper water flow through the unit 4 gallons per minute
- If above two are adequate, disassemble unit and check for debris causing a clog in the unit.
- Call mortech customer service if problem persists

Disposal not functioning

- See troubleshooting in Manufacturer Literature provided



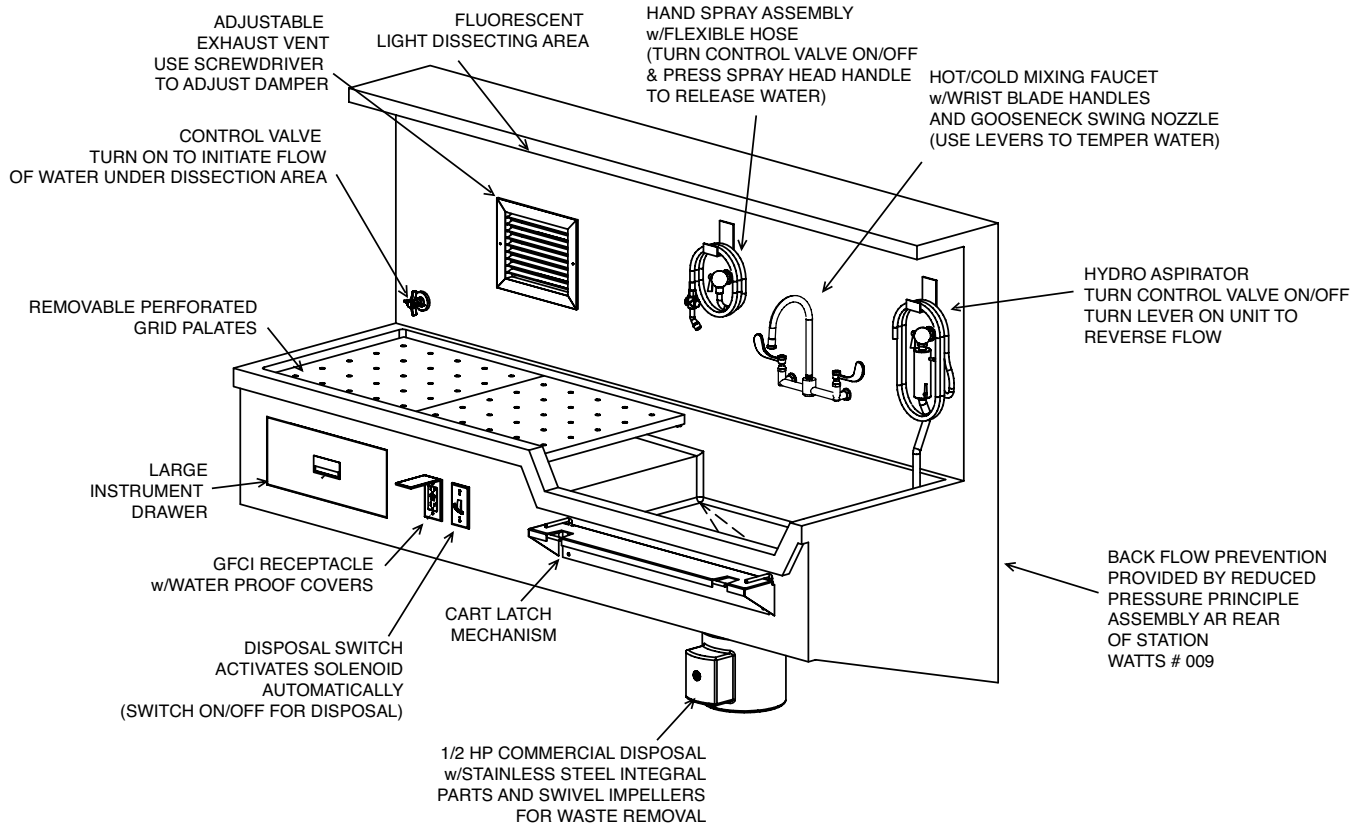
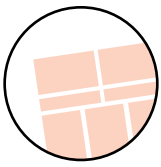

CART LATCH OPERATION

Step 1. (Figure-E) From either side of the carrier cart, open the locking slide rod by moving to the right.

Step 2. (Figure-E) Align cart front legs to match the two notches in the locking mount bracket.

Step 3. (Figure-F) Roll the cart snugly into the notches.

Step 4. (Figure-F) Slide the locking slide rod to the left, locking the cart into position.

Step 5. Lock cart casters for added stability.

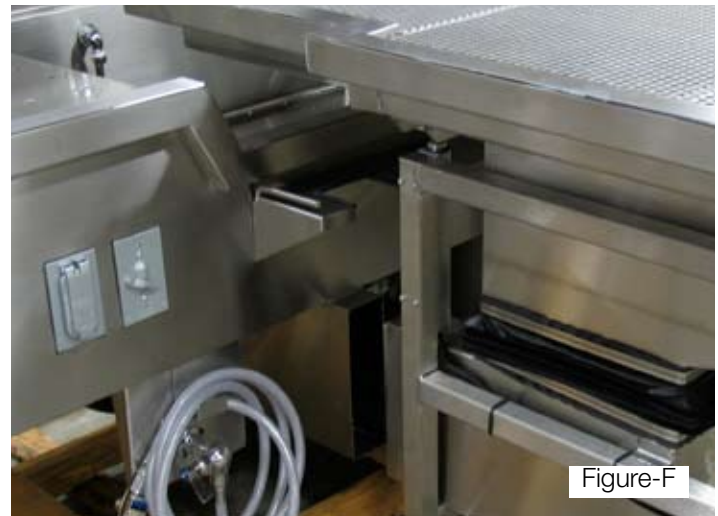

NOTE: HYDRAULIC CARRIERS DO NOT WORK WITH CART LATCH SYSTEMS.

1036-8 Wall Mounted Autopsy Station

Accessories

Scale Shelf

Stainless steel scale shelf attached to front of station for use with various platform type scales. Fabricated to your desired size. Receptacle can be provided to supply power to scale indicator.



Scale Pole and Mounting Bracket

Stainless steel scale pole with mounting bracket for use with standard hanging autopsy scales. Pole can swivel left to right and includes locking knob to keep in desired position. Can be positioned to left, right or center of station depending on your preference.



Raised Dissecting Platform

Model LW380
Size in Inches 24 x 17 x 14
Fabricated entirely of polished stainless steel. Heavy gauge material provides a very stable work surface. Tray creased toward center drain. Drain has hose attachment to route flow to desired location. Height and width suitable for over the body placement.



Evidence Screen

Model LW485
The screen is designed to prevent evidence from being accidentally washed down the drain. It is fabricated entirely from perforated stainless steel with a stainless steel pull handle. It is designed for use in 3.5 inch diameter drains.



Emergency Eyewash Hose Assembly

Hand control spray to provide a gentle of water to rinse eyes of foreign debris. Includes bracket for spray handle and coiled hose.



Organ Rinse Basket

Model LW487
The organ rinse sink basket is designed to hang on the interior of the sink basin and ideal for rinsing organs. It is fabricated of stainless steel with a perforated bottom.



Commercial Grade Waste Disposal Units

Units come standard with 1/2 hp disposal units. Facilities can upgrade to 3/4 hp, 1 or 2 disposal units. Units have all internal stainless steel components and swivel impellers.



Dissecting Boards

Dissecting Boards are manufactured from high density polyethylene which provides an excellent cutting surface. All top edges are chamfered and all bottom corners have a non-skid rubber bumper attached. Color is opaque white.

Size in Inches

24 x 18 x 0.75 thick
18 x 12 x 0.75 thick
20 x 15 x 0.75 thick
20 x 15 x 0.50 thick
Photo Blue Board

Order No.

LW385
LW386
LW387
LW389



IMPORTANT
SOME ACCESSORIES CAN ONLY
BE PROVIDED AT THE TIME OF
ORIGINAL ORDER.





ON-SITE
PARTS & LABOR
WARRANTY

LIGHT DUTY MODEL LC-50

APPLICATION

Designed for light duty foodservice operation in:

- Convenience/grocery store deli's
- Fast food restaurants
- Church/office kitchens
- Bed and breakfast inns

PRODUCT FEATURES & SPECIFICATIONS

- Foodservice design with the ease and flexibility of a household unit
- Disposer mounting included with unit. Mounting fits standard 3-1/2 - 4" (88.9 mm - 101.6 mm) sink opening. No welding required.
- Standard wall switch operates the disposer
- Automatic reversing motor for longer life and trouble-free operation
- Stainless steel grind chamber
- Cast nickel chrome cutting element
- 1-year full warranty from date of installation
- 35 lb. (15.9 kg) shipping weight
- 1/2 HP
- Continuous-duty commercial motor
- 1725 RPM
- 5.8 amps
- Single Phase



DIMENSIONS

1	14-1/4"	361.9 mm
2	3-5/16" min. ID	85.1 mm
3	4-15/16"	125.2 mm
4	3-7/16"	86.8 mm
5	15/16" DIA	24.3 mm
6	7-3/8"	187.1 mm
7	4"	101.6 mm
8	5-3/4"	145.2 mm
9	15/16" ID	33.0 mm

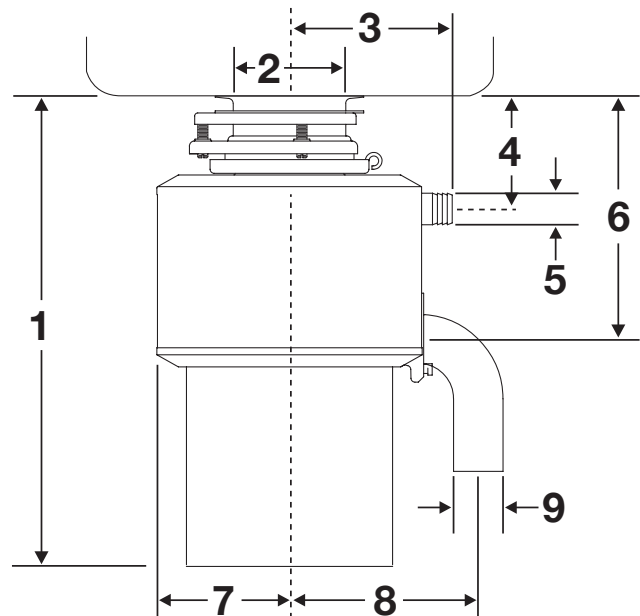

NOTE: Plumb 1-1/2' (38.1 mm) waste line to prevent standing water in disposer motor housing.

SOLENOID

OPERATION

Normally closed: Valve is closed when solenoid is de-energized and opens solenoid is energized.

INSTALLATION

Check nameplate for correct catalog number, pressure, voltage and service.

PIPING

Connect piping to the valve according to markings on valve on valve body.

IMPORTANT: For the protection of the solenoid valve, install a strainer or filter suitable for the service involved in the inlet side as close to the valve as possible. Periodic cleaning is required depending on the service conditions.

WIRING

Wiring must comply with Local and National Electrical Codes.

SOLENOID TEMPERATURE

The solenoid enclosure becomes hot and can be touched with the hand for only an instant.

MAINTENANCE

WARNING: Turn off electrical power and depressurize valve before making repairs. It is necessary to remove valves from pipe for repairs.

CLEANING

A periodic cleaning of all solenoid valves is desirable. The time between cleanings will vary, depending on media and service conditions. In general, if the voltage to the coil is correct, sluggish valve operation, excessive leakage or noise will indicate that cleaning is required.

PREVENTIVE MAINTENANCE

1. Keep the medium flowing through the valve as free from dirt and foreign material as possible.
2. While in service, operate valve at least once a month to insure proper opening and closing.
3. Periodic inspection (depending on media and service conditions) of internal valves parts for damage and excessive



wear is recommended. Thoroughly clean all parts. Replace any parts that are worn or damaged.

COIL REPLACEMENT

Turn off electrical power supply and disconnect coil leads. Process in the following manner:

1. Remove retaining cap or clip, nameplate and cover.
- CAUTION:** When metal retaining clip disengages, it will spring upwards.
2. Remove spring washer, insulating washer and coil. Insulating washers are omitted when a molded coil is used.
 3. Reassemble in reverse order of disassembly paying careful attention to exploded view provided for identification and placement of parts.

CAUTION: Solenoid must be fully reassembled as the housing and internal parts are part of and complete the magnetic circuit. Place insulating washer at each end of coil if required.

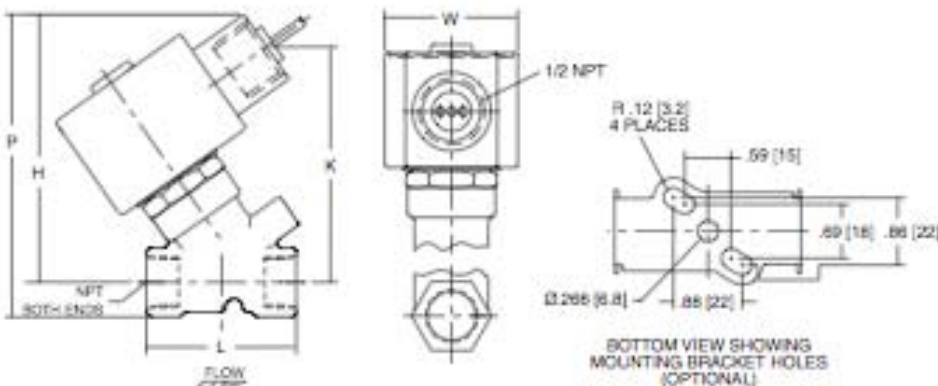

SWITCH

20A, 120/277V, Grounding, Premium Single Pole Toggle Switch, UL, Federal Specification, CSA, Tested To 25000 On/Off Cycles, Screw Pressure Plate Back & Side Wire Termination Accepts #14 Through #10 Awg Stranded & Solid Copper Wire, High Impact Resistant Thermoplastic Constructions, Commercial/Specification Grade, Window Box.

Product Features:

Ground:	Grounding
Amperage:	20 Amp
Voltage:	120/277 Volt
HP Rating:	1HP-120V 2HP-240V-277V
Max Amp:	16 Amp
Termination:	Side
Actuator Material:	Thermoplastic
Body Material:	Thermoplastic
Strap Material:	Steel
Standards and Certifications:	UL/CSA

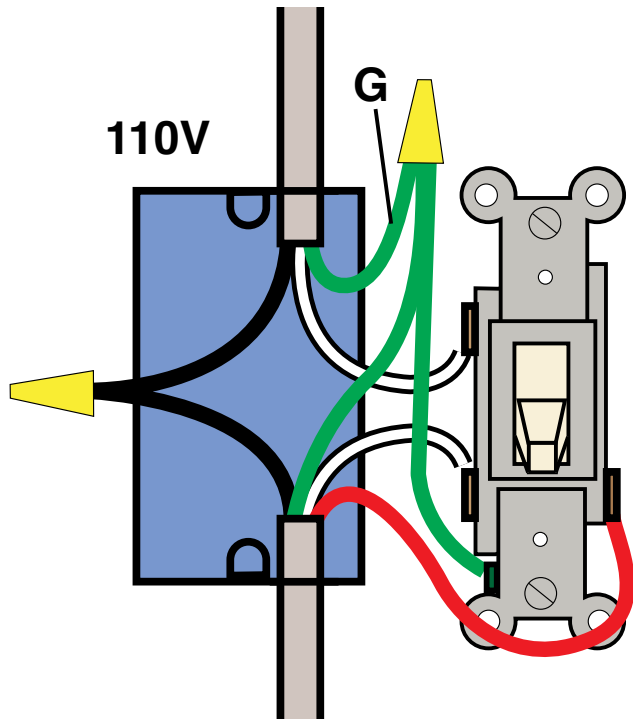

Technical Specifications

LIQUID-TUFF™

UL Liquidtight Flexible Non-Metallic Conduit
(Type LFNC-B)

Scope

This specification covers AFC Cable Systems, Inc. UL LIQUID-TUFF™ Integral Liquidtight Flexible Non-Metallic Conduit, Type LFNC-B designed for use in wet, dry or oily locations as a flame resistant, non-metallic raceway for power, control and communications cables in compliance with Article 356 of the National Electrical Code. The product is UL Listed for 80°C (176°F) in a dry location, 60°C (140°F) in a wet location and 70°C (158°F) in an oily location. It is also UL Listed through 2-inch trade sizes for direct burial, outdoor use and sunlight resistance. In addition the product is CSA certified for use at 75°C (167°F) in dry and oily locations and for minus 18°C (0°F) low temperature applications. This Liquidtight Flexible Non-Metallic Conduit is manufactured and tested in accordance with Underwriters Laboratories Inc. Standard UL 1660 and CSA International Standard CSA C22.2 Number 227.2. The product carries the UL Listing Mark and the CSA Certification Mark.

Construction

Liquidtight Flexible Non-Metallic Conduit, Type LFNC-B is a raceway of circular cross section with a smooth polyvinyl chloride (PVC) inner surface and an integral reinforcing member within the conduit wall. The wall thicknesses and dimensions of the integral conduit shall comply with Table 6.4 of UL 1660 and Table 1B of CSA C22.2 No. 227.2 which are summarized in Table 1.

Grounding

A separate Grounding conductor is required by both the National Electrical Code and the Canadian Electrical Code for all trade sizes.

Markings

The outer surface of the conduit shall be clearly marked with a legible print legend in accordance with UL 1660 and CSA C22.2 No. 227.2.



Performance Tests

The completed UL LIQUID-TUFF™ Liquidtight Flexible Non-Metallic Conduit, Type LFNC-B shall meet all of the performance requirements contained in UL 1660 and CSA C22.2 No. 227.2 and outlined in Appendix A.

- Package lengths in excess of 100' contain splices; these splices must be cut out before use.

Reference Standards

UL 1660	Standard for Liquidtight Flexible Non-Metallic Conduit
CSA C22.2 No. 227.2	Standard for Flexible Liquidtight Non-Metallic Conduit
UL File References NEC@Articles:	UL E123464; CSA 69271 356, 390.15, 501.10(B)(2), 502.10(A)(2), 503.10(A)(2), 511.7(A)(1), 620.21, 645.5(D)(2), 680.21, 680.23, 680.25, 680.27, 680.42, 695.6(E) and 695.14(E)

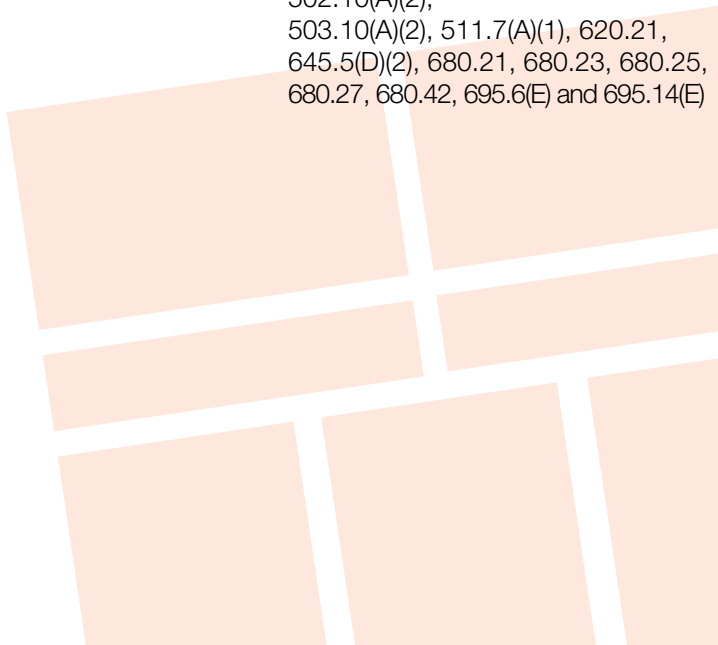

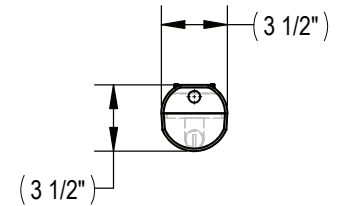
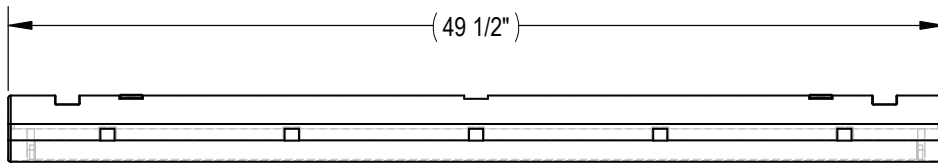

VAPOR TIGHT LIGHT FIXTURE

Provides versatile lighting in line voltage. Frosted glass diffuser eliminates glare for task and accent lighting applications.



FEATURE & SPECIFICATIONS

These fully weatherproof units are designed for use in areas of wet location. Designed to withstand direct contact with rain, these units are corrosion proof and waterproof. Vapor Tight units are ideal in areas such as Car washes, storefronts, parking garages, kitchens and chemical plants.

TECHNICAL SPECIFICATIONS

VTP-R: Premium model (ROUND)

- Specification-Grade
- 120/277 multi-volt electronic ballast
- High-impact, gray polycarbonate housing
- Silicone gasketing provides a seamless seal

VTPR132-120/277 uses one (1) 32-watt T8-type lamp and

- Die-formed galvanized steel mounting brackets
- EZ-Snap Stainless Steel Clip



RECEPTACLE COVER

Type: Vertical

Color: Gray

- Heavy Duty Die Cast Metal Construction
- Patented Quick-Fit™ Key Hole Mount for Easy Installation
- Patented Universal-Fit™ Adapter Technology
- Lockable Tab
- Premium Powdercoat Finish
- Spring Hinge Closure
- UL Listed & 2008 NEC Compliant

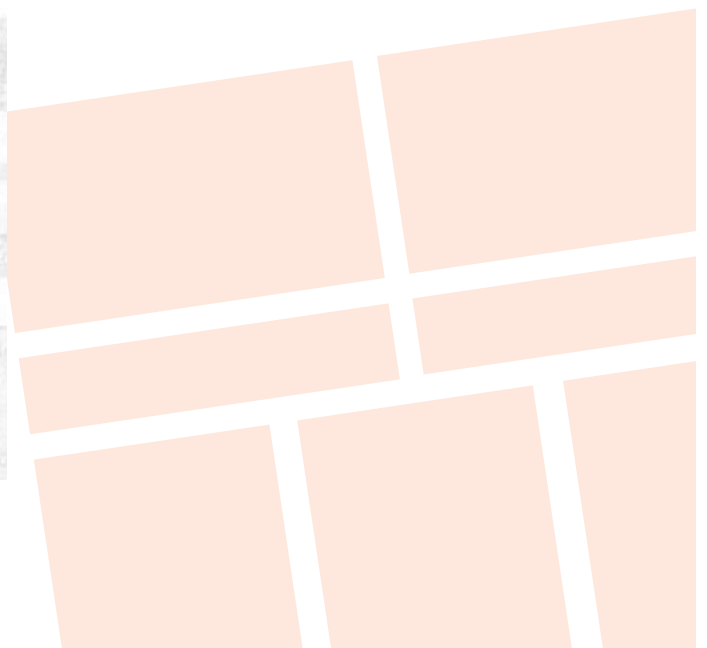
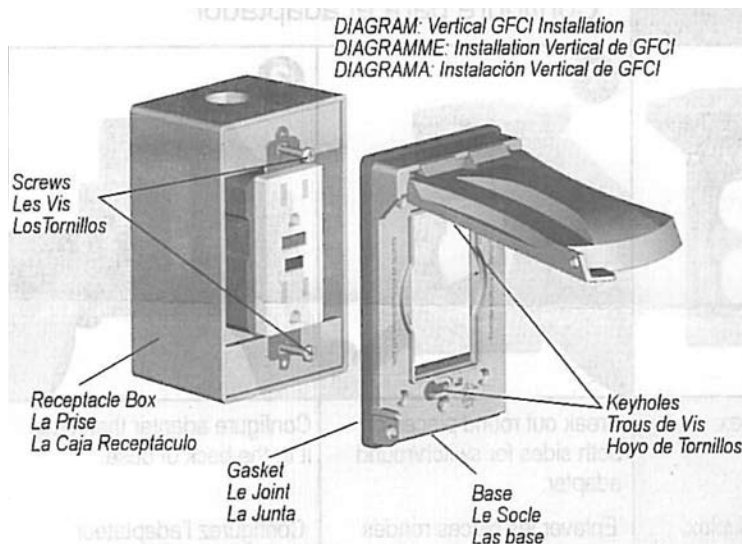

T&S B-0230-LN WALL MOUNT FAUCET

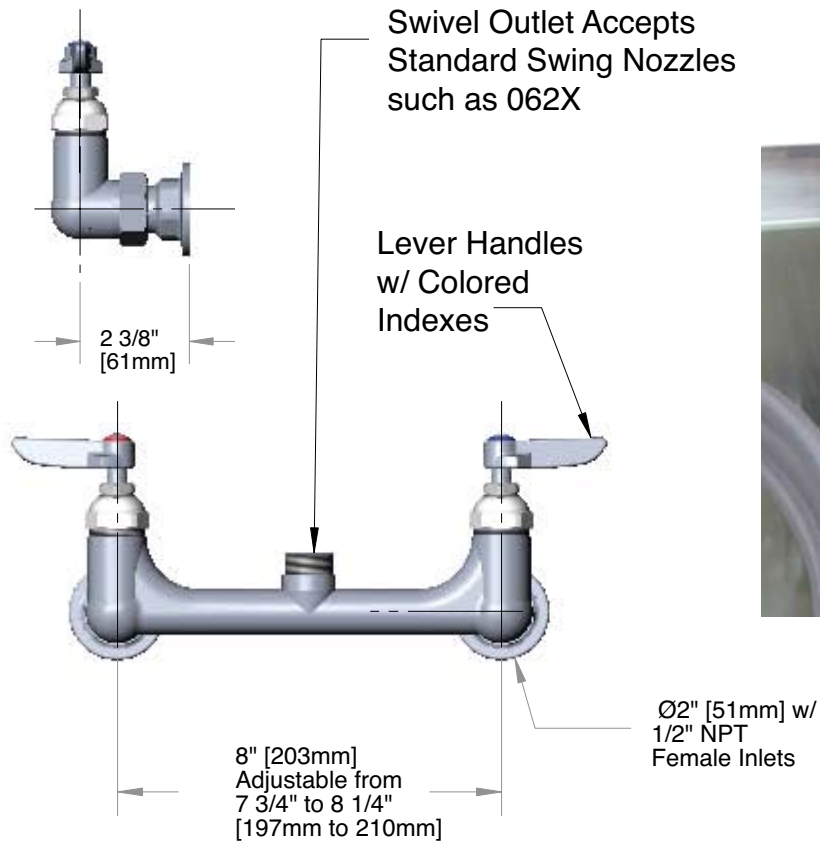

T & S BRASS AND BRONZE WORKS, INC.
MODEL #B-0230 Wall Mount Faucet



T&S SWIVEL GOOSENECK SPIGOT
Model #133X

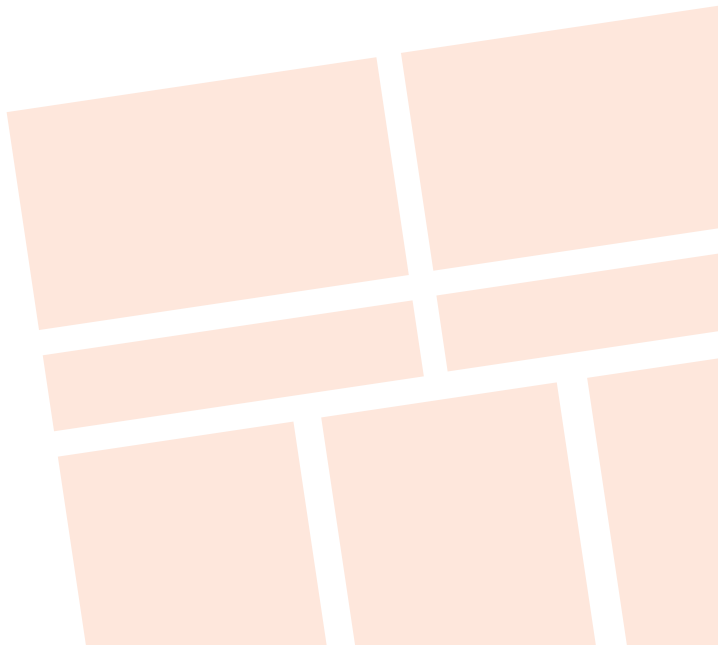
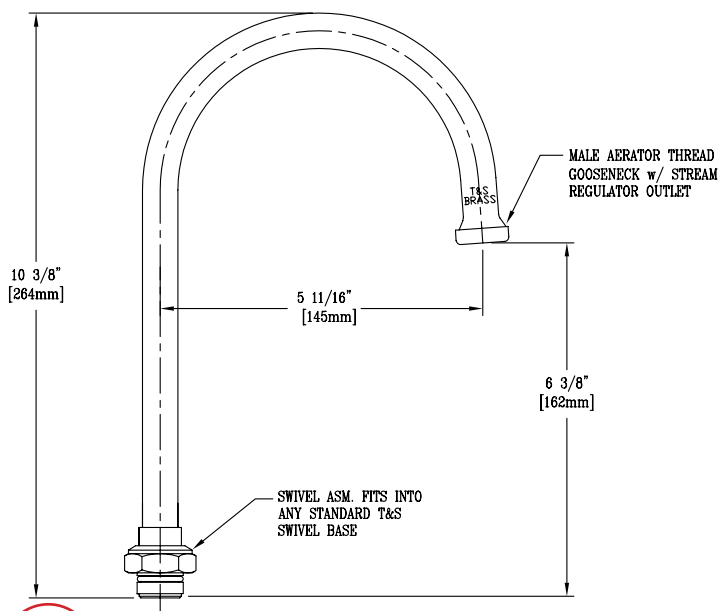

Component Data

ITEM	PART NO.	DESCRIPTION
1	00AA	00AA Flange Asm
2	001019-45	Cplg Nut Washer
3	005959-40	Eterna Barrel Asm-Cold
4	005960-40	Eterna Barrel Asm-Hot
5	177F	Lever Handle
6	000922-45	Lever Handle Screw
7	001660-45	Blue Index-CW
8	001661-45	Red Index-HW

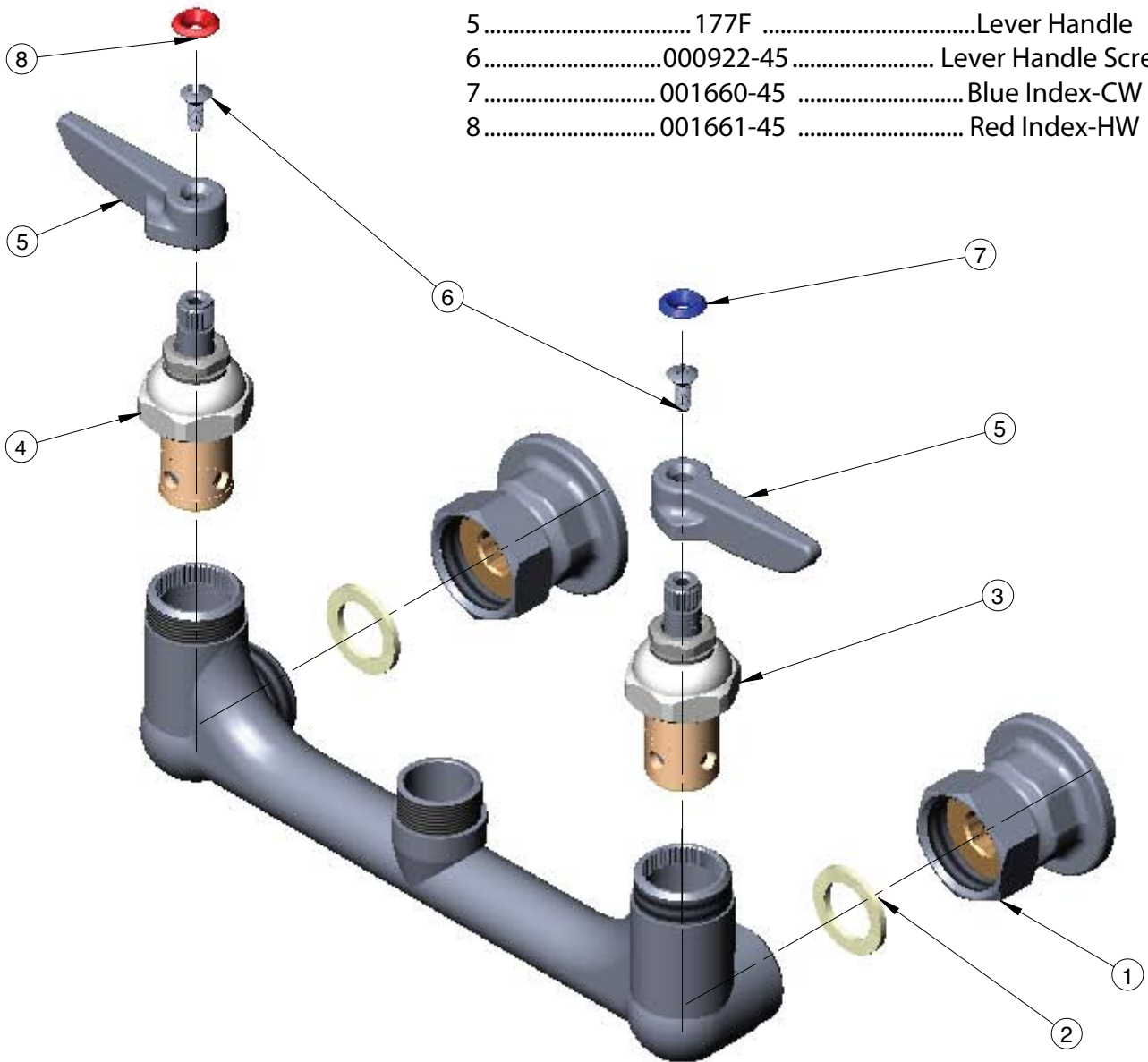

Wye-Pattern, Bronze Strainers

Sizes: 3/4" – (19mm)

Wye-Pattern, Bronze Strainers are designed to protect plumbing system components from dirt, rust and other damaging debris. This series features a tapped retainer cap and closure plug.

Features

- Bronze body
- Wye-pattern
- Tapped retainer cap
- Closure plug
- Special flared screen opening on upstream end to provide unrestricted flow through the strainer

Specifications

A wye-pattern, bronze strainer to be installed as indicated on the plans. The strainer must have a tapped retainer cap and closure plug. Strainer shall be rated to 400psi (27.6 bar) WOG; 125psi (8.6 bar) WSP for sizes 3/8"-2" (10-50mm) and 300psi (20.7 bar) @ 210oF (99oC); 125psi (8.6 bar) WSP @ 353oF (178oC) for sizes 2 1/2"-3" (65-80mm). Strainer shall be a Watts Regulator Company Series 777SI (threaded ends) or S777SI (solder ends).

Materials

Body: Bronze
 Retainer Cap: Brass
 Plug: Bronze
 Gasket: NBR
 Standard Screen: #20 mesh, 304 stainless steel D

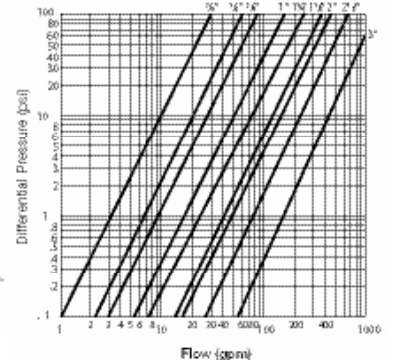
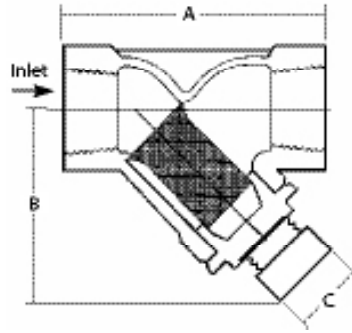

Flow curves show (gpm) and pressure drop (psig) through Watts Series using standard 20 mesh screen.

Dimensions 777SI

SIZE (DN)		DIMENSIONS						WEIGHT	
in.	mm	A		B		C		lbs	kgs
3/4	20	3 3/16	81	1 5/8	42	3/4	6	0.6	0.27



Check periodically for debris. To access the screen remove the filter plug and slide screen out. Remove debris and rinse clean



WYE STRAINER PLUMBED INTO A 1036-10

IMPORTANT

Before Service and Maintenance: Shut water off before checking and cleaning the Wye Strainer fitting screen located inside the fitting.



SERIES 009 Reduced Pressure Zone Assembly - 3/4"

Sizes: 1/4" – 3" (8 – 80mm)

Series 009 Reduced Pressure Zone Assemblies are designed to protect potable water supplies in accordance with national plumbing codes and water authority requirements. This series can be used in a variety of installations, including the prevention of health hazard cross connections in piping systems or for containment at the service line entrance.

This series features two in-line, independent check valves, captured springs and replaceable check seats with an intermediate relief valve. Its compact modular design facilitates easy maintenance and assembly access. Sizes 1/4" – 1" (8 – 25mm) shutoffs have tee handles.

Features

- Single access cover and modular check construction for ease of maintenance
- Top entry - all internals immediately accessible
- Captured springs for safe maintenance
- Internal relief valve for reduced installation clearances
- Replaceable seats for economical repair
- Bronzebody construction for durability 1/4" – 2" (8 – 50mm)
- Ball valve test cocks — screwdriver slotted 1/4" – 2" (8 – 50mm)
- Large body passages provides low pressure drop
- Compact, space saving design
- No special tools required for servicing

Specifications

A Reduced Pressure Zone Assembly shall be installed at each potential health hazard location to prevent backflow due to backsiphonage and/or back pressure. The assembly shall consist of an internal pressure differential relief valve located in

an azone between two positive seating check modules with captured springs and silicone seat discs. Seats and seat discs shall be replaceable in both check modules and the relief valve. There shall be no threads or screws in the waterway exposed to line fluids. Service of all internal components shall be through a single access cover secured with stainless steel bolts. The assembly shall also include two resilient seated isolation valves, four resilient seated test cocks and an air gap drain fitting. The assembly shall meet the requirements of: USC Manual 8th Edition†; ASSE Std. 1013; AWWA Std. C511; CSA B64.4. Shall be a Watts Regulator Co. Series 009.

†Does not indicate approval status. Refer to Page 2 for approved 1

Materials: 1/4" – 2" (8 – 50mm)

Bronze body construction, silicone rubber disc material in the first and second check plus the relief valve. Replaceable polymer check seats for first and second checks. Removable stainless steel relief valve seat. Stainless steel cover bolts. Standardly furnished with NPT body connections. For optional bronze union inlet and outlet connections, specify prefix U (1/2" – 2" (15 – 50mm)). Series 009QT furnished with quarter turn, full port, resilient seated, bronze ball valve shutoffs.

Approvals

ASSE, AWWA, CSA, IAPMO

Approved by the Foundation for Cross-Connection Control and Hydraulic Research at the University of Southern California. Approval models QT, AQT, PC, NRS, OSY. UL Classified 3/4" – 2" (20 – 50mm) (LF models only)

WATTS REGULATOR

USA: 815 Chestnut St., No. Andover, MA 01845-6098

www.wattsreg.com

Canada: 5435 North Service Rd., Burlington, ONT L7L 5H7

www.wattscanada.ca

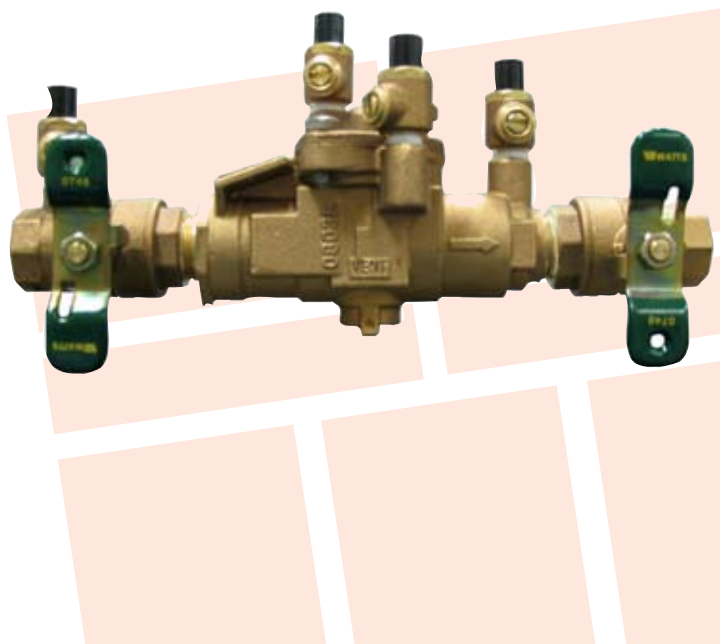



HYDRO-ASPIRATOR

Mandatory operation requirements

- Minimum 1/2" supply line
- Minimum 60 lbs of water pressure
- Minimum 4 gallons per minute of water flow through unit

Vacuum up to 26 inches can be maintained at these pressures. Trocar or aspiration line is attached to the aspiration tube. Diverter handle at lower end must be parallel to length of body of aspirator. To back flush the trocar/aspiration line, turn the diverter handle perpendicular to the length of the aspirator. Tubing can be added to the outlet bottom of the aspirator to direct the flow of water into the sink drain.

- A - VACUUM 3/4-11.5 FAUCET THREAD
 B - 1.500-28 THREAD
 C - 1/8-27 NPS PIPE THREAD
 D - 3/4-32 THREAD
OVERALL ASSEMBLY LENGTH = 5.750 INCHES

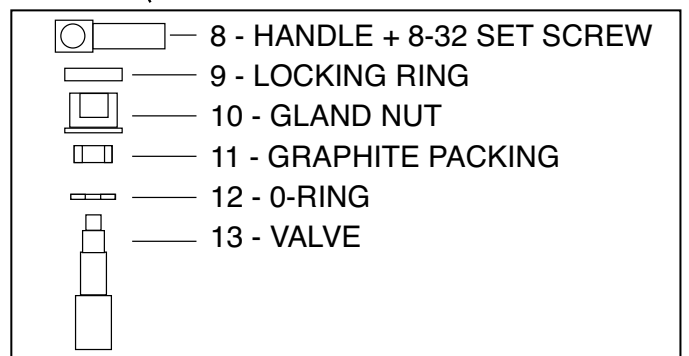
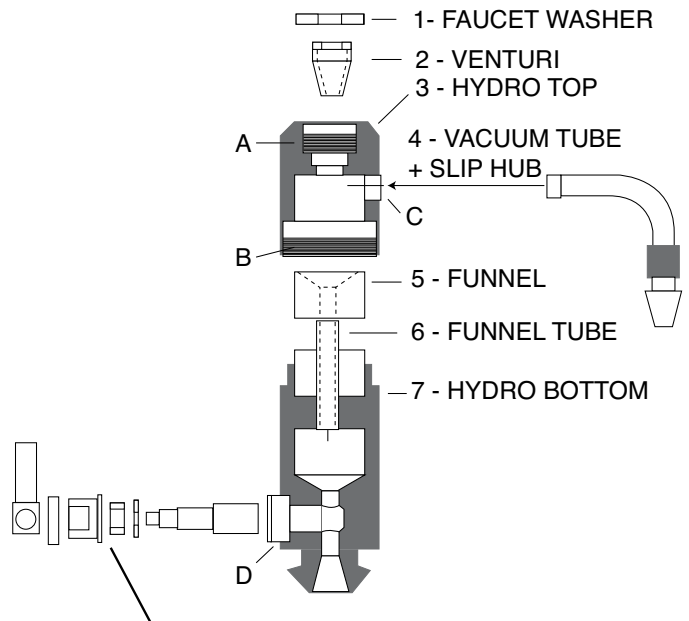

FISHER

SPRAY HOSE ASSEMBLY

SINGLE WALL CONTROL VALVE

Model #2700

SPRAY HEAD

Model #10820

SPRAY HANDLE

Model #2913

SPRAY HOSE

Mortech Model #SH10

ROUGH-IN:

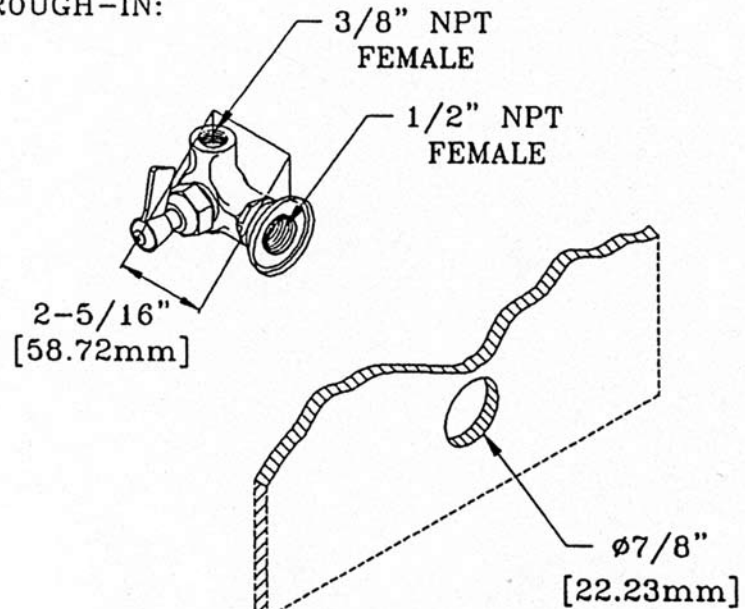

FISHER SINGLE WALL CONTROL VALVE
MODEL # 2700

Feature:

- Single wall
- Stem - right hand
- Swiveling seat disk
- Hot & cold index buttons
- Stainless steel seats
- Stainless steel seat screws
- Stainless steel handle screws

Recommended Settings

- 110°F at 80 psi
System limits
- Temp: 40°F min. to 140°F max.
Pressure 200 psi max. static
- Shipping weight
- 11.5 lbs

Fisher Manufacturing Co.

1900 South "O" Street
Tulare, California 93274
800-421-6162
800-832-8236 FAX

Mailing Address:
P.O.Box 60
Tulare, California 93275

SPRAY HOSE

Mortech Model #SH10



SPRAY HANDLE

Model #2913



SPRAY HEAD

Model #10820

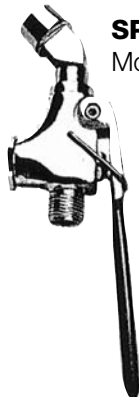

END RINSE ASSEMBLY



T & S BRASS AND BRONZE WORKS, INC.
MODEL # B-1025 End rinse assembly control valve (Figure-A)

(Figure-A)



MODEL # B-1025



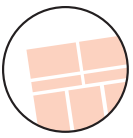

Equipment maintenance

MAINTENANCE INSTRUCTIONS

The unit requires regular maintenance and follow the manufactures directions.

DISINFECTING AND CLEANING

Clean all surfaces of the stainless steel with a hard surface disinfectant/cleaner such as Sheila Shine® or SaniZene®. Follow instructions on container.

DISINFECTING, CLEANING COMPONENTS & ACCESSORIES

Hand wash with disinfecting soap and warm water. Rinse well with clear water and dry with a towel. (Clean on a regular basis to prolong work life).

WARNING

Improper maintenance can cause injury. Maintain only as prescribed in this manual. Overall, it is very simple to maintain. If you use for its intended purpose, it will provide many years of reliable service.

CARE OF STAINLESS STEEL

Stainless steel products have a directional #4 brushed finish. This finish is produced using a very fine abrasive cloth. Dragging heavy equipment across the stainless steel surfaces will cause noticeable scratching. Pitting/corrosion can occur when carbon steel products are allowed to remain in contact with the stainless steel in the presence of moisture. (Examples- Steel Wool pads left in the bottom of the sink). Stainless steel can be damaged by exposure to acids.

TYPES OF SURFACE CONTAMINANTS

- **Dirt** - Consist of accumulated dust and a variety of contaminates. Warm water with or without a gentle detergent is sufficient. Next in order are mild non-abrasive powders such as typical household cleaners. These can be used with warm water, bristle brushes, sponges, or cleaning cloths. (Do not use carbon steel brushes or steel wool they may leave particles embedded on the surface which can lead to RUSTING.) For more aggressive cleaning, a small amount of vinegar can be added to the scouring powder. When water contains mineral solids, which leave water spots, it is advisable to wipe the surface completely with dry towels.
- **Fingerprints and Stains** - Fingerprints and mild stains resulting from normal use are the most common surface contaminates. This affect the appearance and seldom have an effect on corrosion resistance. They can be removed with a glass cleaner or by gentle rubbing with a paste of soda ash (sodium carbonate) and water applied with a soft rag. Followed by a thorough warm water rinse and towel dry.
- **Shop Oil and Grease** - These soils may be corrosive and may not allow the surface to maintain passivity, and so removal is a necessity. Soap or detergent and water may be used or a combination of detergent and water plus a solvent.

TYPES OF CLEANERS AND METHODS

• General Precautions

Avoid using abrasive cleaners unless absolutely necessary. A "soft abrasive," such as pumice, should be used. Many cleaners contain corrosive ingredients, rinse with clean water.

• **Clean Water and Wipe** - A soft cloth and clean warm water should always be the first choice for mild stains, loose dirt and soils. A final rinse with clean water and a dry wipe will eliminate the possibility of water stains.

• **Solvent Cleaning** - Organic solvents can be used to remove fresh fingerprints, oils and greases that have not had time to oxidize or decompose. The preferred solvent is one that does not contain chlorine, such as acetone, methyl alcohol, and mineral spirits.

EFFECTIVE CLEANING METHODS

Commercial Cleaners - Many commercial cleaners compounded from phosphates, synthetic detergents, and alkalis are available for the cleaning of severely soiled or stained stainless surfaces. When used with a variety of cleaning methods, these cleaners can safely provide effective cleaning.

SCRATCH REPAIR

Surface scratches can be repaired using the following technique. Depending on the severity of the scratch, it may be possible to completely remove it. Sand the scratch using 120 grit emery cloth or paper and firm pressure. Always sand in the direction of the grain. Avoid the natural tendency to sand in an arc, instead sand in a perfectly straight line. Sand until the scratch is gone.

Polish using 3M Scotch Brite pads - Very Fine Grade. Use the same motions as with sanding. Polish until the original finish is restored. Wash and wipe the surface completely with dry towels.

RUST REMOVAL

Rust can be repaired using the following technique. Sand the scratch using 120 grit emery cloth or paper and firm pressure. Always sand in the direction of the grain. Avoid the natural tendency to sand in an arc, instead sand in a perfectly straight line. Sand until the rust is gone.

Polish using 3M Scotch Brite pads - Very Fine Grade. Use the same motions as with sanding. Polish until the original finish is restored. Wash and wipe the surface completely with dry towels.

5 Stainless Steel Mistakes NOT to Make When Cleaning

1. Do not use abrasive cleaners that will scratch the surface.

Depending on the surface finish of your stainless steel, abrasive cleaners can cause scratching. A dull finish, probably will not show scratching as much as mirror or highly polished finishes. Test the cleaner in a hidden spot. It's also a good idea to work from the least risky type (water) of cleaning to the heavy duty stuff.

2. **Do not forget to rinse.** Gritty or dirty water can leave a residue on your finish. It can also stain or pit the surface of your stainless steel. Rinse completely. Residue from cleaning solutions left on a stainless steel surface can stain or damage finish.

3. DO NOT USE CLEANERS CONTAINING CHLORINE.

While it may be second nature to bleach everything, stainless steel and chlorine do not mix. Stay away from the bleach when you clean stainless steel. Be aware that bleach can be included in different types of cleaners. If you accidentally get a cleaner on your stainless steel you'll need to rinse it off and quickly.

4. DO NOT USE STEEL WOOL OR STAINLESS BRUSH

These products leave little particles in the surface of the steel and inevitably these particles begin rusting and staining the surface of the steel. They also can excessively scratch the surface of your stainless steel. *Stay completely away from steel wool and steel brushes.*

5. **Do not assume it's the cleaner.** If you do have some spotting or staining, and you've followed all of the rules, it may not be the stainless steel cleaner. Water, especially hard water, can leave spotting and staining on stainless steel surfaces. Towel dry after rinsing can end the problem. Sometimes, even water is an enemy to stainless steel.

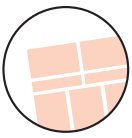

Warranty

WARRANTY

Mortech Manufacturing, Inc. warrants all fabrications to be free of defects due to its own workmanship and materials.

CONTINENTAL UNITED STATES:

Repair and/or replacement of parts furnished that may develop such defects, will be warranted for a period of one year parts replacement and 90 days labor from the date of shipment. Items not manufactured by Mortech Manufacturing will receive the manufacturer's warranty.

INTERNATIONAL:

(For validation of warranty, installation location (physical address) required) Replacement of parts furnished that may develop such defects, will be warranted for a period of (18) months from the date of shipment. Shipping and Labor is not warranted. Items not manufactured by Mortech Manufacturing, Inc. will receive the manufacturer's warranty.

PARTS AND SERVICE

Customer relations and product support are important aspects of Mortech Manufacturing, Inc. For assistance with this or any of our fine products please contact us below:
Mortech Manufacturing, Inc.
411 North Aerojet Avenue
Azusa, CA 91702
TEL (626) 334-1471
FAX (626) 334-1704
www.mortechmfg.com
info@mortechmfg.com

© COPYRIGHT MORTECH MANUFACTURING, INC., ALL RIGHTS RESERVED.

CAUTION

- Inspect unit and all components for any loosening that may have occurred during shipping •

ATTENTION

All images and Drawing in this manual may not represent your model. Refer to your particular project for exact specifications

DISCLAIMER

This manual contains general instructions for the use, operation, and care of this product. The instructions are not all inclusive. Safe and proper use of this product is solely at the discretion of the user. Safety information is included as a service to the user. All other safety measures taken by the user should be within and under consideration of applicable regulations. It is recommended that training on the proper use of this product be provided before using this product in and actual situation.

Retain this manual for future reference. Include it with the product in the event of transfer to new users. Additional free copies are available upon request from Customer Relations.

Mortech Manufacturing, Inc. has made every effort to ensure that this Manual is accurate; Mortech Manufacturing, Inc. abdicate liability for any inaccuracies or omissions that may have occurred.

Information in this Manual is subject to change without notice and does not represent a commitment on the part of Mortech Manufacturing, Inc. Mortech Manufacturing, Inc. assumes no responsibility for any inaccuracies that may be contained in this Manual. Mortech Manufacturing, Inc. makes no commitment to update or keep current the information in this Manual, and reserves the right to make improvements to this Manual and/or to the products described in this Manual, at any time without notice.

If you find information in this manual that is incorrect, misleading, or incomplete, we would appreciate your comments and suggestions.

PROPRIETARY NOTICE

The information in this manual is the property of Mortech Manufacturing, Inc. Mortech Manufacturing, Inc. reserves all patent rights, proprietary design rights, manufacturing rights, reproductions rights, and sales use rights thereto, and to any article disclosed therein except to the extent those rights are expressly granted to others or where not applicable to vendor proprietary parts.

