

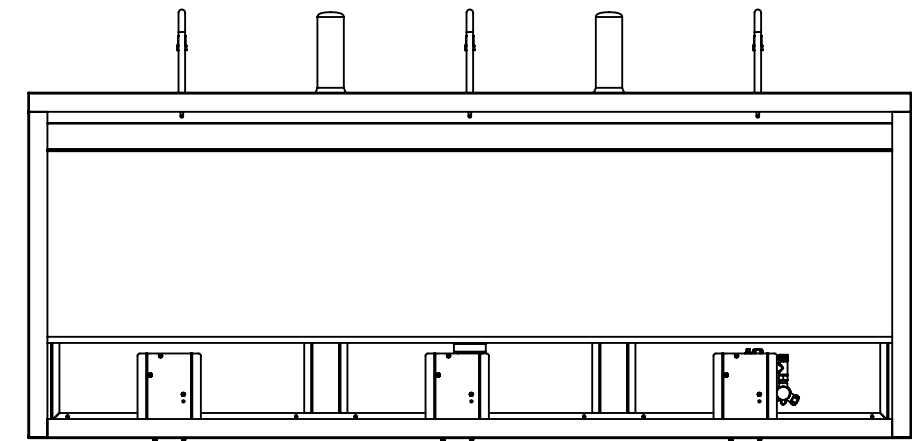

NOTES: UNLESS OTHERWISE SPECIFIED

1. APPLICABLE TO STANDARDS AND SPECIFICATIONS;
ASME Y14.5-2009, DIMENSIONING AND TOLERANCING
ASME Y14.38-2007, ABBREVIATIONS

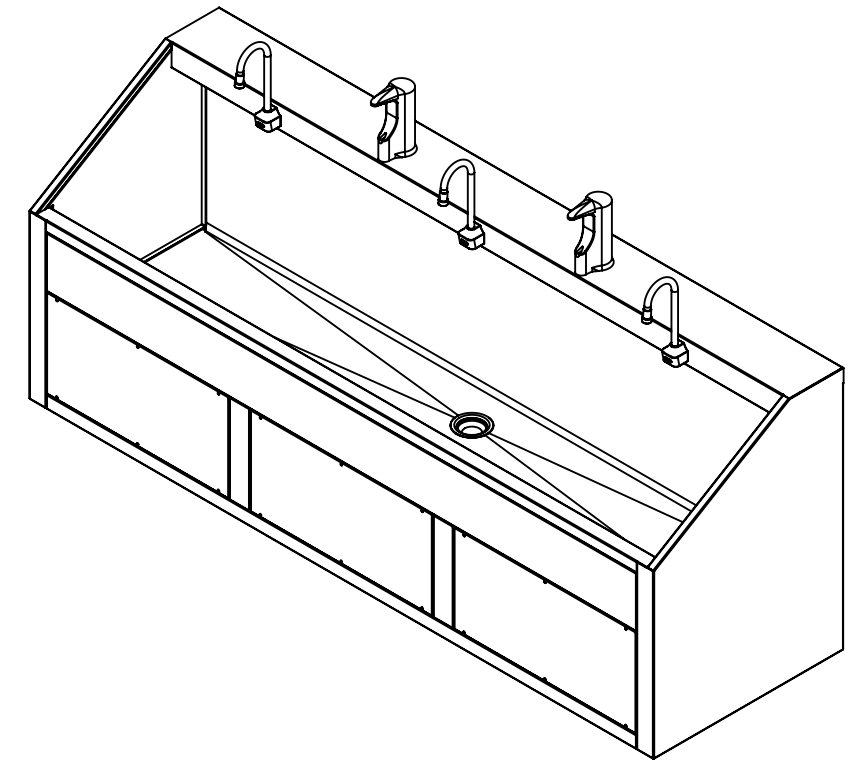
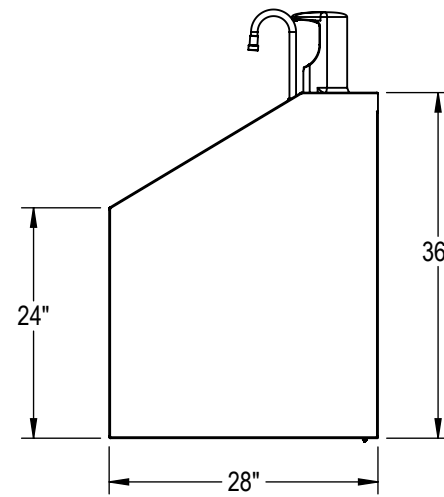
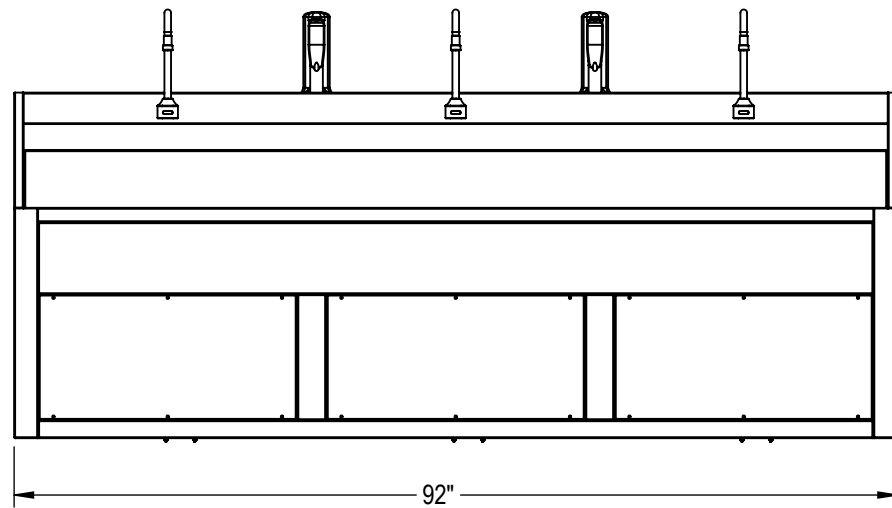
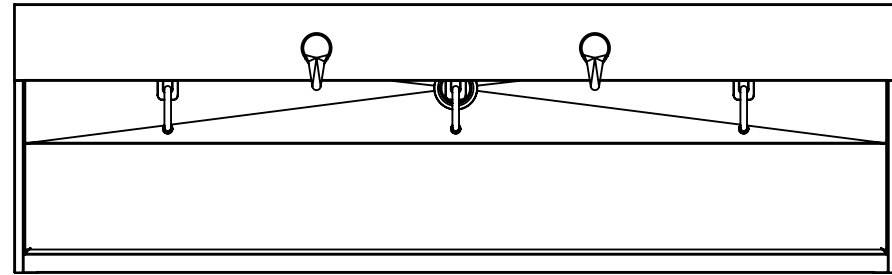

TOLERANCE BLOCK: DIMENSIONS ARE IN INCHES DECIMALS .X ± .1 ANGLES ± 0° 30' DECIMALS .XX ± .06 FRACTIONS ± 1/16" DECIMALS .XXX ± .031		PROPRIETARY THIS DOCUMENT AND THE DATE DISCLOSED HEREIN AND HEREWITH IS NOT TO BE REPRODUCED, USED, OR OTHERWISE DISCLOSED IN WHOLE OR IN PART TO ANYONE WITHOUT WRITTEN AUTHORIZATION FROM MORTECH MFG.		 	
DO NOT SCALE DRAWING MATERIAL 304 STAINLESS STEEL		APPROVALS DATE DRAWN BY CHECKED BY APPROVED BY		TITLE SIZE DWG NO. REV. B SS103 X01	
FINISH #4 SATIN		SCALE NEXT ASSY. 1:20		SHEET 1 OF 2	

NOTES: UNLESS OTHERWISE SPECIFIED

1. APPLICABLE TO STANDARDS AND SPECIFICATIONS;
ASME Y14.5-2009, DIMENSIONING AND TOLERANCING
ASME Y14.38-2007, ABBREVIATIONS

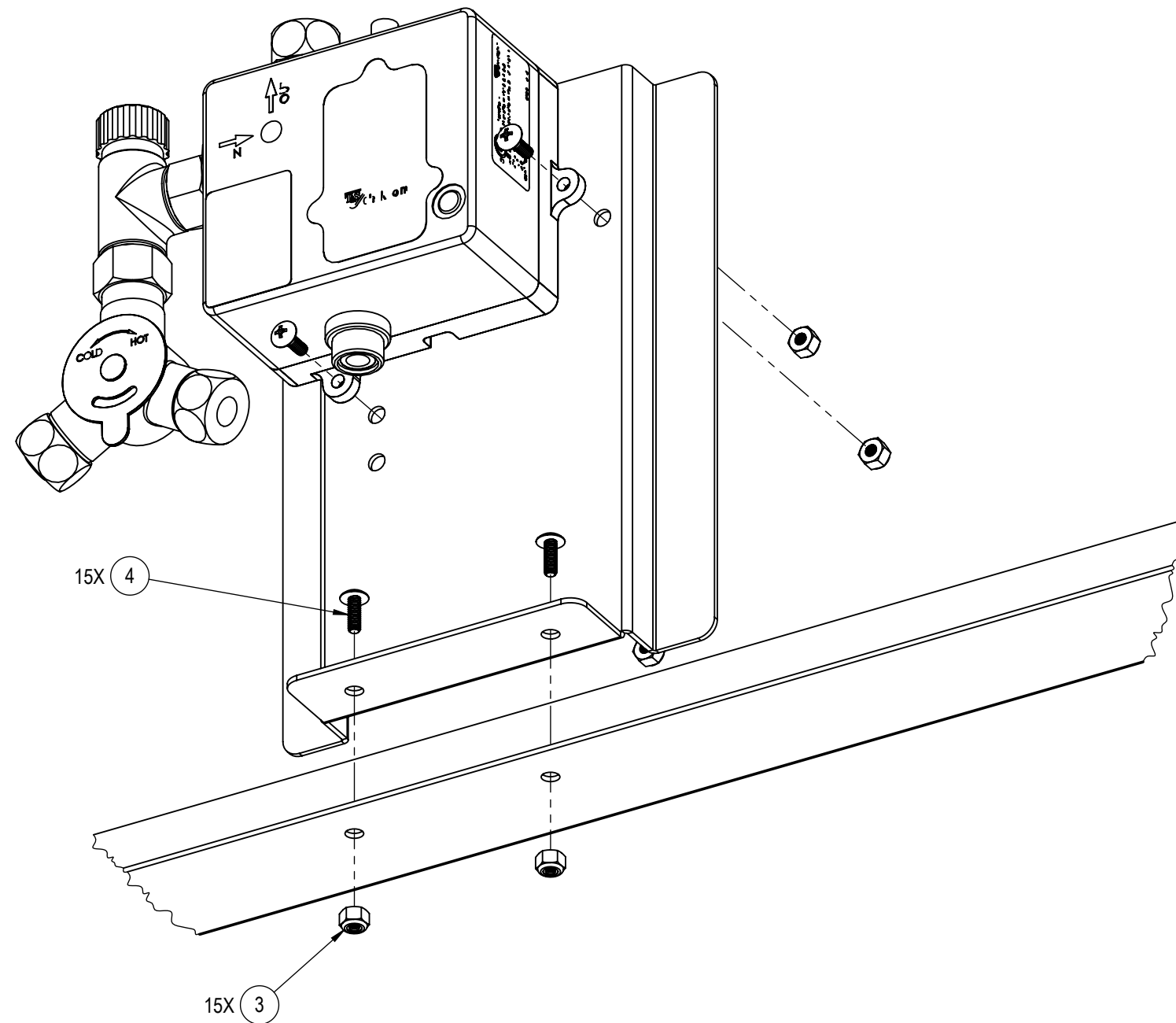

9	3	SS101-ACCESS-PANEL	PANEL, ACCESS- 13.00 X 26.81
8	1	STRAINERS350	STRAINER, SINK- FOR 3.50" OPENING
7	2	DISPENSERSOAP	
6	3	FAUCETWM11	FAUCET, WALL MOUNT- 11" X 4 1/8"
5	1	EC3101_CONTROL	
4	15	SCREWP8325SS	SCREW, PHILLIPS TRUSS HEAD- #8-32 X .500 L, SS
3	15	NUTLK832S	NUT, LOCK- 8-32, WITH NYLON INSERT, SS
2	3	SSH8-8000	
1	1	SS103-7000	TRIPLE SCRUB STATION, W/ HANDS FREE, SUBASSEMBLY
ITEM NO.	QTY.	PART NUMBER	DESCRIPTION

PARTS LIST

TOLERANCE BLOCK: DIMENSIONS ARE IN INCHES DECIMALS .X ± .1 ANGLES ± 0° 30' DECIMALS .XX ± .06 FRACTIONS ± 1/16" DECIMALS .XXX ± .031		PROPRIETARY THIS DOCUMENT AND THE DATE DISCLOSED HEREIN AND HERewith IS NOT TO BE REPRODUCED, USED, OR OTHERWISE DISCLOSED IN WHOLE OR IN PART TO ANYONE WITHOUT WRITTEN AUTHORIZATION FROM MORTECH MFG.		MOPEC GROUP MORTECH ELEVATING PATHOLOGY MANUFACTURING	
DO NOT SCALE DRAWING		APPROVALS	DATE	TITLE	
MATERIAL	DRAWN BY	CHECKED BY	DATE	SIZE	DWG NO.
304 STAINLESS STEEL				B	SS103
FINISH	APPROVED BY			SCALE	REV.
#4 SATIN				1:2	X01
				NEXT ASSY.	SHEET
					2 OF 2